



A Safe Fleet Brand

**LIGHTING
PRODUCTS**

FIRE RESEARCH CORPORATION
26 Southern Blvd., Nesconset, NY 11767
TEL 631.724.8888 FAX 631.360.9727
TOLL FREE 1.800.645.0074
www.fireresearch.com



MODEL CLA200 Series (Amber Light)

SAFETY SUMMARY

FRC lighting products are engineered and manufactured with safety in mind. It is critical that FRC lights are installed, maintained, and operated correctly. Read and understand all instructions before installing, performing maintenance, or operating.

All components, equipment, and installation procedures shall conform to NFPA 1901, *Standard for Automotive Fire Apparatus* and NFPA 70 *National Electrical Code*.

General Safety Precautions

- Do not stare directly at LEDs when power is on.
- Ensure power is off prior to connecting or disconnecting wires/cables and plugs to a power source or performing maintenance.
- Disconnect ground connection from battery marked '-' to avoid accidental short circuits before attempting to connect electrical wires.

Installation Safety Precautions

- Connect the LED light to a 12 or 24 volt DC power source.
- Ensure an appropriate sized circuit protection device is installed (circuit breaker or fuse). See Power Requirements chart below.

INSTALLATION INSTRUCTIONS

Before mounting, check the identification label on the light for specific voltage and current requirements. Check that the length of the wiring is correct. Ensure the CLA200 is mounted so that the lens is focusing the light in the desired direction.

Note: Before drilling holes place the light in position to check for fit. Ensure that the light clears all obstructions.

1. To drill the appropriate mounting hole(s), measure and mark the two mounting hole locations. **Refer to the chart and drawings on page 2 for the mounting hole dimensions of the light being installed.**
2. Attach the mounting brackets using the provided hardware, as indicated in the drawing below.
3. Mount the LED light by using provided hardware to fasten it to your apparatus. If the M6 fasteners (A) are not long enough to attach to your apparatus, it is recommended to use longer fasteners, such as longer length M6 or 1/4 inch (not supplied) with the appropriate nut.

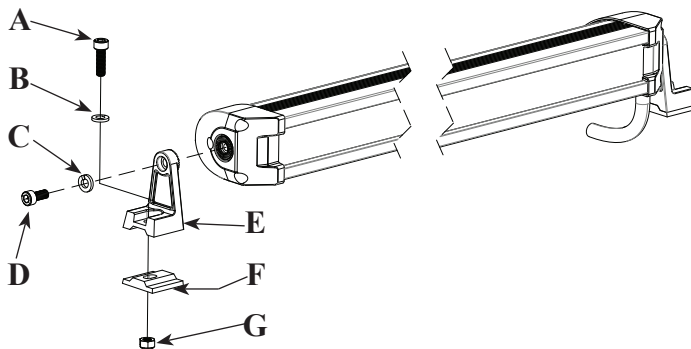

- A. M6 x 20mm Socket Cap Screw
- B. M6 Flat Washer
- C. M6 Lock Washer
- D. M6 x 14mm Socket Cap Screw
- E. Mounting Bracket
- F. Gasket
- G. M6 Nylon Lock Nut

WIRING

		Model Number
Label Name	Wire Color	CLA200-A14
Negative	Black	X
Low Beam	Red	X

NOTE: Lamphead is supplied with a 32" long cable (3/8" OD) with 14 AWG wires.

NOTE: See Power Requirements on page 2.

NOTE: White housing is standard. Available in Black housing as model number with "-B".

Install Crest Light CLA200 Series

CLA200-Rev230613

NOTE: White housing is standard. Available in Black housing as model number with "-B".

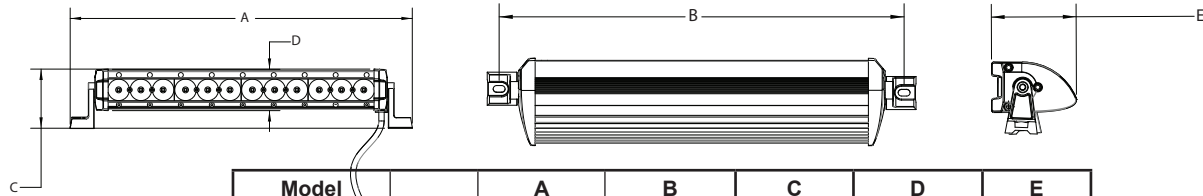
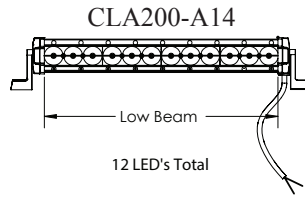

Model		A	B	C	D	E
		Width w/ Bracket	Mounting Holes	Height w/ Bracket	Height w/o Bracket	Depth
CLA200-A14	INCH	17 1/2	16 9/16	3	1 13/16	3 5/16
	MM	444.5	420.7	76.2	46.1	84.1

Power Requirements						
Model	Supply Voltage (VDC)	Marker (Amber) (Watts)	Low Beam (Watts)	Narrow Flood (Watts)	Total Power (Watts)	Output (Lumens)
CLA200-A14	12/24	—	50	—	50	2,600

MAINTENANCE

Use a clean soft cloth, mild soap, and water to clean the lens.

NOTE: FRC LED lampheads use Lexan lenses and cleaning with abrasive materials, solvents, or most chemical cleaners can cause lens surface degradation and reduced performance of the light. *Some chemicals will cause the lens to become brittle and prone to cracking.*

NOTE: Do not use Loctite on any screws near the lamphead lens. FRC LED lampheads use Lexan lenses that can become brittle and prone to cracking when exposed to Loctite compounds.