

**FRC**

A Safe Fleet Brand

**INSIGHT****PORTABLE  
FLOWTESTER  
MODELS: FTA400 GPM, FTA410 LPM****FIRE RESEARCH CORPORATION**[www.fireresearch.com](http://www.fireresearch.com)

26 Southern Blvd., Nesconset, NY 11767

TEL 631.724.8888 FAX 631.360.9727 TOLL FREE 1.800.645.0074

# CONTENTS

## Table of Contents

CONTENTS.....	2
List of Tables.....	3
List of Figures.....	3
INTRODUCTION .....	4
Overview.....	4
Features.....	4
Specifications.....	5
GENERAL DESCRIPTION .....	6
Components .....	6
TYPICAL APPLICATIONS .....	8
Hydrant Total Flow Test .....	8
Pump Test.....	9
Nozzle Test.....	10
Training.....	10
Calibrate a Vehicle Mounted Flowmeter .....	10
FLOW RATE MEASURING INFORMATION .....	11
POWER.....	12
Internal Battery .....	12
Alternate Power Sources.....	12
OPERATION .....	13
Program Features .....	13
Flow Test.....	14
Totalized Flow .....	15
PROGRAMMING .....	16
Inputs .....	16
Program Access Mode .....	17
Program Code Descriptions.....	18
Enter Sensor/Tube Size.....	22
CALIBRATION.....	24
FLOW SENSOR MAINTENANCE.....	26
PARTS LIST .....	27

---

## List of Tables

Table 1. Values for K With a 2.5" Flow Tube .....	8
Table 2. Flowmeter Calibration Flow for Each Pipe Size .....	11
Table 3. Program Code Quick Reference .....	18

## List of Figures

Figure 1. Controls and Indicators.....	7
Figure 2. Typical Programming Displays .....	16
Figure 3. Sensor/Tube Size Program Displays .....	23
Figure 4. Flow Sensor Maintenance .....	26
Figure 5. Parts List.....	27

---

# INTRODUCTION

## Overview

The **INSIGHT Portable FlowTester** is an instrument that will measure flow rate directly without using charts or doing calculations. The tester is designed around the **FRC INSIGHT** digital flowmeter and a paddlewheel type flow sensor mounted in a flow tube. The flow tester program allows for up to six different calibration schemes to be set in memory. This enables the operator to press a button and use the same portable tester with different size flow tubes.

The **Portable FlowTester** consists of a Pelican case into which a panel is mounted containing an **INSIGHT** digital flowmeter, a power switch, low battery indicator, and cable connections. The Pelican case also contains a rechargeable battery and an AC charger/power supply. A slot cutout in the front panel allows for the storage of cables.

The **INSIGHT** digital flowmeter has a 4-digit LED flow display with daylight bright digits 0.56 inch high. The flowmeter electronics are self contained and program features are accessed via push buttons on the front of the module. Flow rate information is provided from the paddlewheel flow sensor mounted in a flow tube. This information is processed and shown on the digital display as flow rate.

The **Portable FlowTester** can be powered by its internal rechargeable 12 volt battery, a 120/240 VAC source, or an external 12/24 VDC source (with optional cable). The battery charging unit is mounted inside the box. To charge the internal battery plug the cable into the AC CHARGER input on the front panel and connect the other end to a 120/240 VAC electrical outlet.

**Note:** The **Portable FlowTester** must be ordered from the factory set for 240 VAC and 24 VDC operation.

All controls, indicators, and input connections are located on the front panel.

## Features

- Field Programmable
- Multiple Flow Rate Calibration Points
- Uses Multiple Diameter Flow Tubes
- High and Low Flow Warnings
- Totalizing Flow Function

## Specifications

Operating and storage temperatures of the flow tester is limited by the battery used. The standard FRC provided battery has a life of 3 - 5 years under the following temperature conditions.

Storage Temperature: 0 to 185 °F (-18 to 85 °C)

Operating Temperature: 0 to 125 °F (-18 to 50 °C)

### Display Module

Supply Voltage: 9 - 30 VDC

Supply Current: 0.5 Amp

Operating Time: 8 Hours with a fully charged battery at 75°F. Can be extended by supplying the external +12V DC or 120V AC (Charging) power supply.

Operating Temperature: Rated for -20°F to +150°F ambient for all electronic components, including the LED Flow display module.

**Note:** Battery capacity drops to 50% below 33°F (0°C)

### Flow Tube

Material: Aluminum

Sizes Available:

FTA400-015	1.5" Tube w/2.5" Couplings	(13 - 320 GPM)
FTA400-020	2.0" Tube w/2.5" Couplings	(21 - 520 GPM)
FTA400-025	2.5" Tube w/2.5" Couplings	(30 - 850 GPM)
FTA400-030	3.0" Tube w/NPT Threads	(40- 1380 GPM)
FTA400-040	4.0" Tube w/NPT Threads	(80 - 2300 GPM)

**Note:** GPM rating is at 0 PSI back pressure (no obstruction at end of tube).

**Note:** Maximum pressure must not exceed 300 PSI.

### Flow Sensor

Type: Paddlewheel

Sensor Material: Acetal (Delrin) with Stainless Steel (316) Shaft

Excitation Voltage: 5 VDC

---

# GENERAL DESCRIPTION

## Components

The **INSIGHT Portable FlowTester** consists of the following components:

Case

Digital Flowmeter Display

Battery and Charger

Flow Tube(s)

Paddlewheel Flow Sensor and Sensor Housing Assembly

Cables

### Case

Mounted inside the Pelican case is a panel that has a digital flowmeter display module, power switch, low battery indicator, and input cable connectors installed. The case also houses a rechargeable battery and an AC charger/power supply. A slot cutout in the front panel allows for the storage of cables. All controls and indicators are located on the front panel. (Refer to Controls and Indicators.)

### Digital Flowmeter Display Module

The flowmeter display module contains a digital display, two buttons and an LED. It also houses the electronics and programs that are used to operate the portable tester. The programs are accessed and inputs are made by using two buttons on the front of the display module.

### Battery and Charger

The battery and charger used in the tester is a maintenance free, sealed lead acid battery. If any problems occur with any of the charging circuits, or if it is found during a test that the battery is not charged, it is possible to power the unit directly from either a 120/240 VAC or a 12/24 VDC source. (Refer to Power section.)

**Note:** The **Portable FlowTester** must be ordered from the factory set for 240 VAC and 24 VDC operation.

### Flow Tube(s)

The tester can store in memory calibration data for up to six flow tubes. Each flow tube will have a mount for a paddlewheel flow sensor.

### Paddlewheel Flow Sensor

The flow sensor provides an input signal to the display module that is proportional to the flow rate through the tube. It is mounted in the discharge end of the tube. The electrical connector is waterproof and molded into the flow sensor housing.

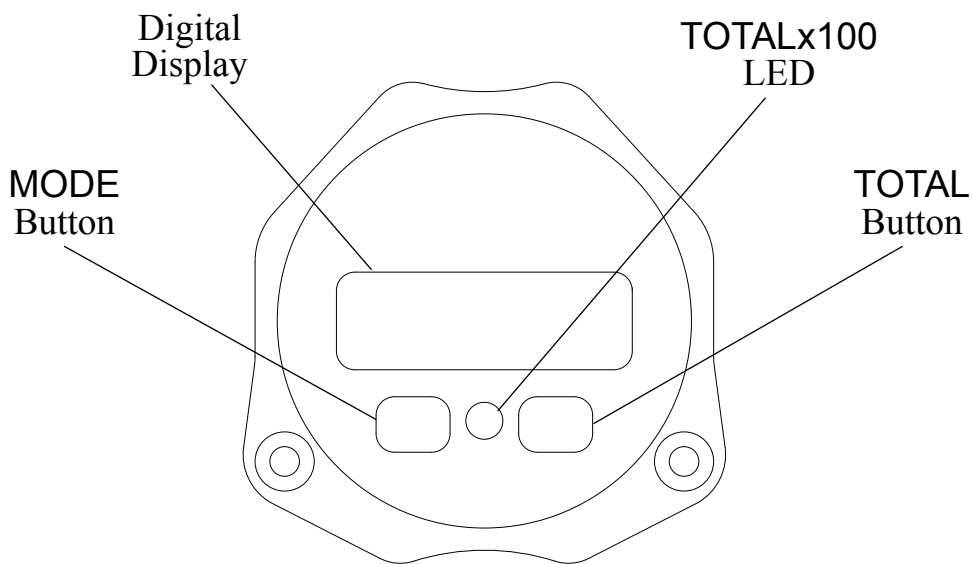
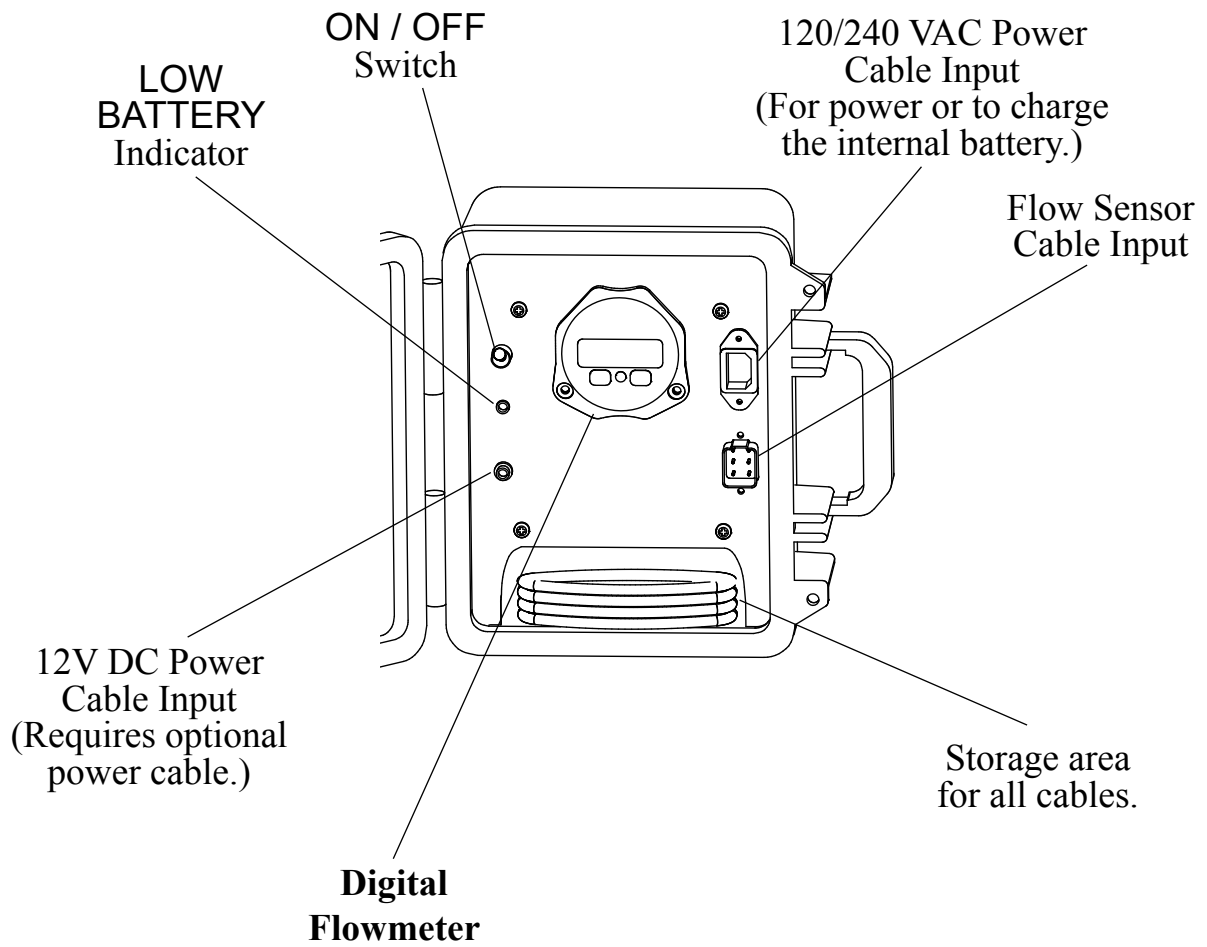

**Figure 1. Controls and Indicators**

# TYPICAL APPLICATIONS

## Hydrant Total Flow Test

A direct reading of flow in Gallons Per Minute (GPM) can be obtained by connecting the portable flow tester to a discharge, flow water and record the flow displayed. The tester can also be used (employing some simple math) to find the total output of a hydrant. This can be accomplished by recording the differences in flow out of one discharge as other ports on the hydrant are opened.

The hydrant test method described below assumes the use of a portable flow tester with a 2.5" flow tube. If a different size tube is used, the mathematical calculations below would need to be adjusted.

The Portable FlowTester may be connected to the 2.5" hydrant port in order to obtain individual hydrant flow measurements. Other ports may be opened as desired. To conduct this test, proceed as follows:

1. Connect the flow tube to a 2.5" port. (Adapters are not supplied.)
2. Open the hydrant valve and record the flow reading.
3. Shut off the hydrant and remove the other 2.5" cap.
4. Open the hydrant valve and record the flow reading.

**Note:** This reading will be lower than the first reading as the water is now being discharged from two ports.

5. If the hydrant has a steamer port, open that and record the flow as above.

If more than one port is opened, the total actual flow will be higher than the displayed flow, but it will be in proportion to the opened port areas. The actual flow can be determined by multiplying the displayed flow by a **K factor** such that:

$$\text{Total Actual Flow} = \text{Displayed Flow} \times \mathbf{K}$$

Use the values for **K** in Table 1 to determine actual estimated flow.

**Table 1. Values for K With a 2.5" Flow Tube**

<b>PORTS OPENED</b>	<b>K</b>
One 2.5" port with 2.5" flowmeter attached	1.00
Two 2.5" ports, one with 2.5" flowmeter attached	2.00
One 2.5" with 2.5" flowmeter attached and one 4.5" LDH	4.24
Two 2.5", one with 2.5" flowmeter attached and one 4.5" LDH	5.24



For different size flow tubes the value for K that is used to determine total flow out of the hydrant will be different than those shown in Table 1. Use the following formula to determine new value for K.

$$\text{Constant K} = \frac{\text{Total Flow Area}}{\text{Area of Flow Tube Opening}}$$

Total Flow Area = Finding the sum of the areas of all open discharges.  
(Area of a circle is  $\pi r^2$ )

**K factor** are used as multipliers to determine total flow out of a hydrant when the portable flow tester is hooked up to only one port of the hydrant, but water is flowing out of more than one.

## Pump Test

The **Portable Flow Tester** can be used to test pumpers not only from draft but also from the tank or from a hydrant. It is extremely valuable to know not only that your pumper can pass the service test, but remember it is necessary to know your capabilities on the fire ground.

Make sure your pump can supply your preconnected lines with enough water from the tank, if that is the way you expect to use them. For in-line pump testing, attach the portable flow tester to the hydrant and run a typical hose layout. Next, extend your standard fire fighting lines and open them. Monitor the flow.

For the service type of test, connect three lines into a common manifold. On the discharge of the manifold connect a short length of hose leading into the portable flow tester. Attach another length of hose on the discharge side and connect this to a deck gun or monitor. If the monitor incorporates a sufficient straight length, with an integral stream straightener, then the tester may be attached on to the discharge end of the monitor in lieu of the nozzle.

Test the pumper according to the certification pressure, RPM, and volume or pressure pump settings. To do that, set the RPM and then adjust the pump pressure by adjusting the discharge valves. Correct the RPM if it has changed and readjust the pressure if that has changed. When you are at the correct pressure and RPM point, note the flow. The flow should meet the pumper rating at that pressure and RPM.

---

## Nozzle Test

Attach a hose to the inlet of the flow tube and the nozzle to be tested on the discharge of the flow tube. The nozzle may be either a smooth bore type or automatic. Flow the nozzle at various pressures and note the flow and pressure displayed on the readout. This test will provide a vivid depiction of the nozzle pressure/flow relationship.

## Training

Use the **Portable Flow Tester** in training sessions to show firemen the effects of pressure and flow on hose handling, reach of stream, the effects of kinked hose, etc. as pumper pressure and nozzle sizes are changed.

Install the flow tube in the line behind the nozzle, preferably not directly on to the discharge port of the pumper. Both the nozzleman and the pump operator vary their valves. It is now possible to monitor the flow and thus determine the optimum flow for various situations. This will be a graphic presentation of interaction of pressure, flow, and nozzles. It will also demonstrate the desirability of Fire Research Flow and Pressure Testers, which have been specifically designed for the fire industry, particularly in the case where automatic nozzles are used.

## Calibrate a Vehicle Mounted Flowmeter

1. Connect the portable flow tester flow tube to the pump suction port. (Refer to Figure 2.)
2. Lay a 2 1/2" hose from the discharge to be tested to the flow tube making sure there is no kink in the hose.
3. With the pump engaged open the discharge gate slowly all the way.
4. Control the flow with the suction port valve and by changing the RPM if needed.
5. Read the displayed flow on the tester flowmeter.

**Note:** Refer to the vehicle flowmeter manufacturer's instructions to determine how to adjust the calibration of the vehicle mounted flowmeter.

6. Have an assistant calibrate the vehicle flowmeter to match the reading on the tester flowmeter.

## FLOW RATE MEASURING INFORMATION

- The location of the flow sensor in the plumbing system is critical. The flow at and around the sensor must be laminar, or smooth, to ensure accurate flow rate measurement. There must be enough straight pipe run before the flow sensor location to allow the stream to stabilize into a uniform flow.
- Plumbing systems are always unique and may cause small deviations in the factory flowmeter calibrations. It is recommended to check flowmeter calibration after installation.
- Flowmeters should be checked from time to time for accuracy and recalibrated as necessary. Calibrate at the most frequently used flow rate or use the guidelines provided by NFPA 1901. (Refer to Table 2.)
- Plumbing components upstream of a flow sensor that tend to increase stream turbulence may cause erroneous flow rate readings. Typical components would include a valve, flange or elbow, sudden or multiple bends in the piping, or an increase in pipe diameter. In these cases it may be require that a short length of hose (perhaps a 10 foot section) be installed upstream of the portable flow tester flow tube to stabilize the flow. (The hose diameter must be the same as the flow tube diameter.)

**Table 2. Flowmeter Calibration Flow for Each Pipe Size**

**Note:** (Reference NFPA 1901) Each flowmeter shall be calibrated to an accuracy of  $\pm 5$  percent when flowing the amount of water shown for the pipe size in which it is mounted.

<u>Pipe Size</u>		<u>Flow</u>	
<u>Inch</u>	<u>mm</u>	<u>GPM</u>	<u>LPM</u>
1	25	40	150
1.5	38	90	340
2	52	160	600
2.5	65	250	950
3	75	375	1400
4	100	625	2400
5	125	1000	4000
6	150	1440	5500

---

# POWER

## Internal Battery

**IMPORTANT :** Before using the **Portable Flow Tester** for the first time, the battery must be charged for at least six (6) hours.

The **Portable FlowTester** is powered by a rechargeable battery and must be charged regularly. A fully charged battery will provide approximately six hours of operating time. When the tester is not in use, the ON/OFF switch should be left in the OFF position. The LOW BATTERY WHEN LIT indicator will illuminate when the battery needs to be charged.

### Charging

**Note:** The **Portable FlowTester** must be ordered from the factory set for 240 VAC and 24 VDC operation.

A charger is mounted inside the box. A 120/240 VAC power cable is supplied to power the charger. To charge the internal battery plug the cable into the AC CHARGER input on the front panel and connect the other end to a standard AC electrical outlet.

**The battery must be charged with the ON/OFF switch in the OFF position.**

### Replacing the Battery

The battery used in the tester is a 12 VDC, 3.4 Ah, maintenance free, sealed lead acid battery. The battery should last 3 to 4 years depending on use.

(To install a battery do these steps in reverse.) To remove the battery:

1. Remove the four retaining screws on the bottom of the flow tester case.
2. Open the cover and lift out the front panel.
3. Remove the two screws holding the battery to the front panel.
4. Remove the wires from the battery terminals.

## Alternate Power Sources

If any problems occur with any of the charging circuits, or if it is found during a test that the battery is not charged, it is possible to power the tester directly from either a 120/240 VAC or a 12/24 VDC source.

The tester will operate normally and can be used to perform flow tests when connected to an AC power source. Plug the AC Power Cable into the AC CHARGER input on the front panel and connect the other end to a standard AC electrical outlet. The flow tester will work from the internal DC power supply.

A 12/24 VDC power source (car or truck battery) can also be used to power the flow tester. Plug the optional DC Power Cable into the EXTERNAL POWER DC VOLTAGE input on the front panel and connect the other end to a DC source.

**Caution:** Care should be taken not to drop the flow tube. Dropping the flow tube could result in damage the exterior of the tube or the flow sensor.

**Note:** Before using the **Portable FlowTester** for the first time, it must be charged for at least six (6) hours.

The battery used in the tester is a maintenance free, sealed, lead acid battery. If any problems occur with any of the charging circuits, or if it is found during a test that the battery is not charged, it is possible to power the unit directly from either a 120/240 VAC or a 12/24 VDC source. (Refer to Power section.)

It is recommended that the calibration of the meter be checked once annually or if the operator feels that the reading might be erroneous.

## **Program Features**

See Programming section for more detailed information.

### **High and Low Flow Warning (Codes 315 and 316)**

When the flow rate is above the programmed high flow value a flashing -HI- will show in the digital display. When the flow rate is below the programmed low flow value a flashing -LO- will show in the digital display.

### **Flow Cutoff (Codes 318 or 319)**

The digital display will show 0 when the flow rate goes below the programmed flow cutoff value.

# Flow Test

## Set-up

**Note:** FRC does not provide adapters for connecting flow tubes. Use appropriate adapters as necessary.

1. Ensure the tester battery is charged or connect it to an alternate power source.

**Note:** The flow sensor is positioned at the discharge end of the flow tube.

2. Attach a water source to the intake side of the flow tube. Best results is obtained by a short run (perhaps 10 feet) of relatively straight hose from the source to the flow tube.
3. On the discharge side of the flow tube attach a hose, a nozzle, a quarter turn ball valve, or leave free depending on the type of test.
4. Connect the flow sensor cable between flow tube sensor and the sensor input on the front panel of the tester.
5. Place **ON/OFF** switch to **ON** the display flashes the calibration/tube size program. After 3 seconds the display switches to show 0 GPM.
6. Press **MODE** button to display the current sensor/tube size program.
7. If the sensor/tube size program is correct, press and hold **MODE** button until the display begins to flash, release the button and proceed with the flow tests.
8. If the sensor/tube size program is not correct, select the correct program.

## Select Sensor/Tube Size

**Note:** The sensor/tube size programs must be pre-entered into memory and calibrated. (Refer to Programming section.) If a sensor/tube size had been entered but not calibrated it can not be selected. (Refer to Calibration section.)

1. Press **MODE** button to display the current sensor/tube size program.
2. Each time the **MODE** button is pressed the display shows the next available program.
3. When the desired program is shown in the display, press and hold **MODE** button until the display begins to flash.
4. Release **MODE** button to select the sensor/tube size program.
5. Proceed with the flow tests.

---

## Totalized Flow

The total button is used to perform two functions, display total flow and reset the totalized flow to 0 if the reset function is set to YES.

### Display Total Flow

When the **TOTAL** button is pressed and released the digital display shows the total accumulated flow and the **TOTALx100** LED is on. (The flow will be x 100 the number shown in the display.)

Press and release the button again to show normal flow rate.

The total continues to accumulate even if power has been off unless the reset function is enabled.

### Reset Total Flow to 0

The totalizer reset function (code 317) has two program settings YES or no. (Refer to Programming section.) To enable the reset function the program totalizer reset is set to YES.

Totalized flow will reset and start from 0 when power is off. Flow total can be reset to 0 during operations by displaying the total flow and then pressing and holding the **TOTAL** button until the display shows 0.

## PROGRAMMING

The program access mode is selected and inputs are made by using the two buttons on the front of the flowmeter display module. The digital display will show stored data and operator inputs. (Refer to Figure 2.)

**Note:** When entering codes in the program access mode there is a timeout feature that requires an operator input be made every three seconds. If an input is not detected at a button within three seconds the program will return to normal operation.

### Inputs

The two buttons on the front of the display module allow the operator to gain access to stored data and program functions.

The **MODE** button is used to display and select the calibration/tube size program. Both the **MODE** and **TOTAL** buttons are used to enter a program code.

Once a program code is entered the **MODE** button is used to select the digit to be changed and the **TOTAL** button is used to change the digit or option choice.

#### PROGRAM ACCESS MODE DISPLAYS

Mode Selected:		Ready for program code to be entered.
Entering Code:		Ready for first digit of code to be entered.
Code Entered:		Valid three digit code.
Automatic:		Programmed value or option is shown.
Change Option:		New program value or option is selected.
Exit Mode:		Ready for another program code to be entered or return to normal operation.
Error Code:		Shows if an invalid program code has been entered.

**Note:** Refer to Program Access Mode for detailed information.

**Figure 2. Typical Programming Displays**



## Program Access Mode

To gain access to the program features a three digit program code must be entered. Review the Program Code Descriptions or refer to Table 3. Program Code Quick Reference for the proper three digit code.

**Note:** There is a timeout feature that will return the program to normal operation in three seconds if input is not detected at the buttons.

### Select Program Access Mode

Turn on power. Press the **MODE** button and hold it until the display shows four dashes. The program access mode is ready for a three digit program code to be input.

### Enter Program Code

**Note:** There is a timeout feature that returns the program to normal operation in three seconds if input is not detected at the buttons.

1. Select the Program Access Mode (four dashes are shown in the display).
2. Press the **MODE** button. The display shows the number 100 and the first digit 1 will flash. Each time the **MODE** button is pressed the number will scroll up by 1. Set the first digit to the number desired.
3. Press the **TOTAL** button. The second digit shown in the display flashes. Each time the **TOTAL** button is pressed the number scrolls up by 1. Set the second digit to the number desired.
4. Press the **MODE** button. The third digit shown in the display flashes. Each time the **MODE** button is pressed the number scrolls up by 1. Set the third digit to the number desired.

When a valid three digit program code is entered the display shows a program value or an option. If an invalid code is entered the display shows an error code.

**Note:** When a valid code has been entered and the display shows a programmed value or an option, the timeout feature is disabled.

### Change Values or Options

Press the **MODE** button to select the digit that is to be changed. The digit flashes. Press the **TOTAL** button to change the digit or the option choice.

### Exit Program Access Mode

Press both the **MODE** and **TOTAL** buttons and hold them until four dashes are shown in the display. Release the buttons and enter a new code or after 3 seconds the program times out and returns to normal operation.

## Program Code Descriptions

When a valid three digit program code has been entered a program value or option will show in the display. The **MODE** and **TOTAL** buttons are used change the data.

The **MODE** button will select the digit that is to be changed. The digit will flash.

The **TOTAL** button will change the digit that is flashing or change the option choice.

Table 3 provides a quick reference of the program codes.

**Table 3. Program Code Quick Reference**

CODE	FEATURE	OPTIONS
311	Flow Rate Increment	Increment by 1, or 10
312	Sensor/Tube Size	A,b,c,d,E,F (with tube size)
313	Flow Rate Units	F1=GPM, F2=LPM
315	High Flow Warning	0 to 9999 (0 = disabled)
316	Low Flow Warning	0 to 9999 (0 = disabled)
317	Totalizer Reset	YES=Reset, no=store total flow
318	Flow Cutoff (Frequency)	0 to 99.9
319	Flow Cutoff (Flow Rate )	0 to 999
321	Flow Calibration	Calibrate at one flow rate
322	Flow Calibration	Calibrate at two to ten flow rates
E202	Invalid Code Entered	Re-enter code
E204	No Flow Sensor Signal	Check water flow and wiring
E206	Invalid Calibration Point	Select different point
E208	Memory Failure	Contact FRC

- Refer to Program Code Descriptions for detailed information.
- There is a timeout feature that will return the program to normal operation in three seconds if input is not detected at the buttons.
- When a valid code has been entered and a programed value or option is shown in the display, the timeout feature is disabled.

### Code 311 Flow Rate Increment

Factory programmed value: 

Options: 0000 to 9999

This code will allow a program value to be set where the digital display will change from increments of 1 to increments of 10. The display will increment by 1 at flow rates below the program setting and by 10 at flow rates above the program setting. Settings of this code will not impact flow warnings, flow cutoff settings, or flow rate display when in the calibration program.

### Code 312 Sensor/Tube Size

Factory programmed value:  (--- = Tube Size)

Options: A, b, c, d, E, F (With Any Tube Size)

This code will allow the flow tester to be programmed for up to six different sensor/tube sizes. Each is identified with a sensor identifying letter (A thru F) and the tube size. The sensor/tube sizes are entered into memory by setting the program slot and doing the calibration procedure. Once the tester is programmed the operator presses the mode button to select a different sensor/tube size. (**Note:** Tube can refer to pipes, fittings, or other fixtures that the flow sensor may be mounted in.)

**Note:** Tube size is in inches or millimeters depending on code 313 setting.

### Code 313 Flow Rate Units

Options: F1 (GPM); F2 (LPM)

This code will allow the display to show flow rate in GPM or LPM.

### Code 315 High Flow Warning

Factory programmed value:0 (High flow warning is disabled.)

Options: 0001 to 9999

This code will allow the high flow warning to be set. When the flow rate is above the high flow warning program value, the flow display will alternately flash between the flow rate and -HI-.

### Code 316 Low Flow Warning

Factory programmed value:0 (Low flow warning is disabled.)

Options: 0001 to 9999

This code will allow the low flow rate warning to be set. When the flow rate is below the low flow warning program value, the flow display will alternately flash between the flow rate and -LO- .

---

### Code 317 Totalizer Reset

Factory programmed value: 

Options: YES, no

This code will toggle the flow totalizer reset function on and off. The totalizer reset function has two program settings YES and no. For the reset function to work the totalizer reset is set to YES. Flow total will reset and start from 0 when power is applied to the display module. Flow total will reset to 0 when the **TOTAL** button is pressed and held. When the totalizer reset is set to no, the flow totals will accumulate and will not reset to 0, even when power is off.

### Code 318 Flow Cutoff (Frequency)

Factory programmed value: 

Options: 0 to 99.9 Hz

This code allows a cutoff frequency for the flow sensor to be set. There is always some turbulence in the pipe that could cause the flow sensor to turn with the discharge closed. This would cause the display to show a flow rate when there is no true flow. The flow cutoff function is set so that the flow display will show 0 when the signal from the flow sensor is below the programmed value.

### Code 319 Flow Cutoff (Flow Rate)

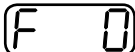
Factory programmed value: 

Options: 0 to 999

This code allows a cutoff flow rate for the flow sensor to be set. There is always some turbulence in the pipe that could cause the flow sensor to turn with the discharge closed. This would cause the display to show a flow rate when there is no true flow. The flow cutoff function is set so that the flow display will show 0 when the signal from the flow sensor is below the programmed value.

### Code 321 Flow Calibration (Single Point)

Factory programmed value: Precalibrated to Pipe Size

Options: 1 Calibration Point

Refer to Calibration section.

### Code 322 Flow Calibration (Multiple Point)

Factory programmed value: No Values Entered

Options: 2 to 10 Calibration Points

This code allows for the display to be calibrated at multiple flow rates. This function should be used when the flow sensor is installed in a difficult plumbing location where flow is not linear. It corrects for nonlinear flow to provide an accurate flow rate display.

Refer to Calibration section.

---

**Error Code E202**

An invalid program code has been entered. Re-enter program code when the digital display resets.

**Error Code E204**

There is no signal from the sensor. This code will only be displayed when in a calibration mode. Troubleshoot the sensor and the associated wiring.

**Error Code E206**

A selected calibration point is too close to the previous point. (There is less than 5% difference between two calibration points.) Select a different point to continue with the calibration procedure.

**Error Code E208**

There is a failure with the internal memory of the module. Contact FRC if this error code is displayed.

**Exit Program Access Mode**

Press both the **MODE** and **TOTAL** buttons and hold them there until four dashes are shown in the display. Release the buttons and after 3 seconds the program will return to normal operation.

---

## Enter Sensor/Tube Size

The **Portable FlowTester** program allows for up to six different sensor/tube sizes to be set in memory. Each is identified with a sensor identifying letter (A thru F) and the tube size.

**Note:** Tube can refer to pipes, fittings, or other fixtures that the flow sensor may be mounted in.

The tester is programmed and calibrated at the factory for the sensor(s) and tube(s) it is shipped with.

A sensor/tube size is programmed into memory by selecting an identifying letter (A thru F) for the sensor, entering the tube size, and doing the calibration procedure. The calibration procedure must be done for each sensor/tube size. If a sensor/tube size had been entered but not calibrated it can not be selected when performing flow test.

1. Place **ON/OFF** switch to **ON** the display flashes the sensor/tube size program. After 3 seconds the meter switches to show 0 GPM.

2. Enter code 312.

Result: The display shows the default sensor/tube size.

3. Press the **MODE** button to select the digit that is to be changed. The digit flashes.

4. Press the **TOTAL** button to change the digit.

5. Enter the identification letter and tube size. (Unused slots are set at 0.0.)

6. Press both the **MODE** and **TOTAL** buttons and hold them until four dashes are shown in the display. Release the buttons and enter a new code or after 3 seconds the program times out and returns to normal operation.

**Note:** All additions or changes in this program require calibration.

7. Perform the calibration procedure for the sensor/tube size.

There are six Sensor/Tube Size program slots. They are identified by a letter and the tube size. Each program is calibrated to be used with a specific sensor and tube. The tube size will be displayed in inches or millimeters depending on code 313 setting.

The display format is as follows:

- 1st - A x.x
  - 2nd - b x.x
  - 3rd - c x.x
  - 4th - d x.x
  - 5th - E x.x
  - 6th - F x.x
- (x.x = Tube Size)

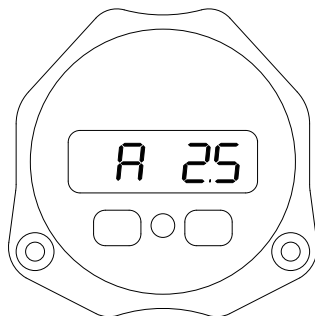

Sensor A with  
2.5" Tube

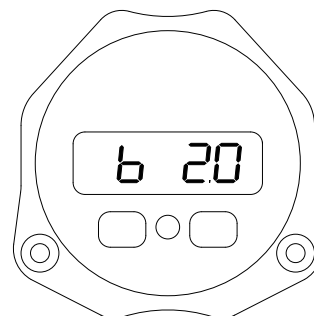

Sensor b with  
2.0" Tube

**Figure 3. Sensor/Tube Size Program Displays**

---

# CALIBRATION

The **Portable FlowTester** is programmed and calibrated at the factory for the tube(s) that it is shipped with. Each new sensor/tube size program that is entered needs to be calibrated.

It is recommended that the tester be checked for accuracy annually and recalibrated as necessary. The calibration must be checked for all sensor/tube size programs that are stored in memory.

To calibrate the digital flowmeter use a precalibrated water flow test kit or a Pitot gauge as a reference.

## Notes:

Fully charge the battery before calibrating.

Ensure the flow sensor paddlewheel is clean and the spins freely.

Review the Programming section for details on using the Program Access Mode.

## Flow Calibration, Single Point (Code 321)

Calibrate at the most frequently used flow rate or use the guidelines provided by NFPA 1901. (Refer to Table 3.)

1. Enter code 321.

Result: The digital display shows the default sensor/tube size program.

2. Press the **TOTAL** button to change the sensor/tube size program.
3. Press both the **MODE** and **TOTAL** buttons and hold them until 0 is shown in the display. Release the buttons.
4. Flow water through the tube at the flow rate selected for the calibration point. Ensure a constant pressure is maintained to obtain a steady flow rate.
5. Adjust the tester displayed flow rate to match the reference flow rate.  
Use the **MODE** button to select the digit that is to be changed. The digit flashes.  
Use the **TOTAL** button to change the value of the flashing digit.
6. Press both the **MODE** and **TOTAL** buttons and hold them until four dashes are shown in the display. Release the buttons and enter a new code or after 3 seconds the program times out and returns to normal operation.
7. Vary the water flow through the discharge and ensure the displayed flow rate matches the reference. If there are differences at other flow rates the multiple point flow calibration may be necessary.



---

## Flow Calibration, Multiple Point (Code 322)

This function allows for the tester to be calibrated at multiple flow rates. It corrects for nonlinear flow to provide an accurate flow rate display.

Select flow rates to calibrate (up to 10 calibration points) that are within the most commonly used flow range.

**Note:** There must be at least a 5% difference between each calibration point.

If a selected calibration point is too close to the previous point an E206 error code will show on the display.

1. Enter code 322.

Result: The digital display shows the default sensor/tube size program

2. Press the **TOTAL** button to change the sensor/tube size program. Repeatedly pressing the **TOTAL** button will result in cycling through pipe 'A' through 'F' and then back to pipe 'A'. Select the pipe being calibrated.
3. Press both the **MODE** and **TOTAL** buttons and hold them until **Pt1** is shown in the display. Release the buttons.

Result: The flowmeter program is ready to set the first calibration point.

4. Flow water through the tube at the flow rate selected for the calibration point. Ensure a constant pressure is maintained to obtain a steady flow rate.
5. Press the **MODE** button.

Result: The display shows a flow rate with the last digit flashing.

6. Adjust the displayed flow rate to match the reference flow rate.  
Use the **MODE** button to select the digit that is to be changed. The digit flashes.  
Use the **TOTAL** button to change the value of the flashing digit.
7. Press the **MODE** button. While holding down the **MODE** button, press and release the **TOTAL** button. Then release the **MODE** button last. (If the buttons are pressed too long the program will exit the calibration mode.)

Result: The display shows **Pt2** (or the next calibration point).

8. Repeat steps 4 through 7 for each flow rate to be calibrated.
9. To exit the calibration program:

Press the **MODE** button first, and then the **TOTAL** button. Hold both until four dashes are shown in the display. Release both buttons and enter a new code, or after 3 seconds the program will time out and return to normal operation.

## FLOW SENSOR MAINTENANCE

It is recommended that the flow sensor be cleaned during the yearly calibration check.

Depending on the environment that the flow tube is used in, it is possible that mud, grass, algae, or other materials may collect on the paddlewheel of the flow sensor and require it to be cleaned from time to time.

Remove the flow sensor and clean the it with a mild soap and clean water. Make sure the paddlewheel spins freely.

### Remove Flow Sensor

1. Remove retaining nut.
2. Slide flow sensor out of sensor housing.

### Install Flow Sensor

1. Insert flow sensor into sensor housing. Align flat spot on sensor rim with alignment tab and make sure O-Ring is in groove.

**Note:** The retainer cap only needs to be hand tightened. There is an inside lip that will stop the cap from turning when it makes contact with the alignment tab. This provides the correct pressure to make the seal at the O-Ring. Make sure the flow sensor does not disengage from the alignment tab and rotate.

2. Install retainer cap and hand tighten.

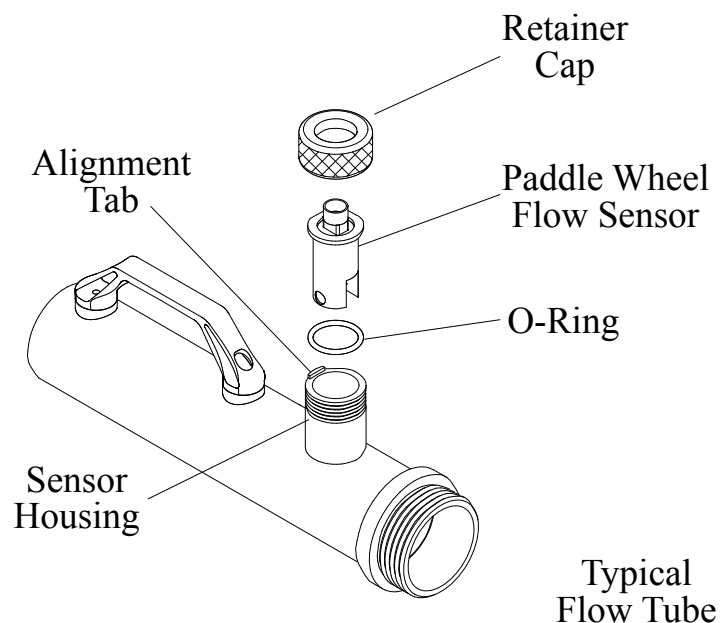

**Figure 4. Flow Sensor Maintenance**

## PARTS LIST

Index	FRC Part No.	Description
1	FTA400-XXX FTA410-XXX	Portable FlowTester (GPM) Portable FlowTester (LPM) XXX = Tube Diameter
2	XE-FTPWRUSA-C	. Power Cable, Type K, 120 VAC
3	ZBT-172-ND	. Battery, Rechargeable, 12 VDC
3	XE-FM015FT1-M	Flow Tube, 1.5-in w/2.5 Couplings
	XE-FM020FT1-M	Flow Tube, 2.0-in w/2.5 Couplings
	XE-FM025FT1-M	Flow Tube, 2.5-in w/2.5 Couplings
	XE-FM030FT1-M	Flow Tube, 3.0-in w/NPT Threads
	XE-FM040FT1-M	Flow Tube, 4.0-in w/NPT Threads
4	XE-MF15P-S	. Paddlewheel Flow Sensor
5	XE-FTIPF-C	. Cable, Flow Sensor
6	XE-FTC12V-A	DC Power Cable (Optional)



Figure 5. Parts List



### **PERSONAL RESPONSIBILITY CODE**

The member companies of FEMSA that provide emergency response equipment and services want responders to know and understand the following:

1. Firefighting and Emergency Response are inherently dangerous activities requiring proper training in their hazards and the use of extreme caution at all times.
2. It is your responsibility to read and understand any user's instructions, including purpose and limitations, provided with any piece of equipment you may be called upon to use.
3. It is your responsibility to know that you have been properly trained in Firefighting and/or Emergency Response and in the use, precautions, and care of any equipment you may be called upon to use.
4. It is your responsibility to be in proper physical condition and to maintain the personal skill level required to operate any equipment you may be called upon to use.
5. It is your responsibility to know that your equipment is in operable condition and has been maintained in accordance with the manufacturer's instructions.
6. Failure to follow these guidelines may result in death, burns or other severe injury.



Fire and Emergency Manufacturers and Services Association, Inc.  
P.O. Box 147, Lynnfield, MA 01940 [www.FEMSA.org](http://www.FEMSA.org)

Copyright 2006 FEMSA. All Rights Reserved