



A Safe Fleet Brand



# INTERCOM SYSTEM

## Model ICA900



**Push-To-Talk  
Control Module**



**Speaker Box**



**Hands Free  
Control Module**

**FIRE RESEARCH CORPORATION**

[www.fireresearch.com](http://www.fireresearch.com)

26 Southern Blvd., Nesconset, NY 11767

TEL 631.724.8888 FAX 631.360.9727 TOLL FREE 1.800.645.0074

# CONTENTS

## Table of Contents

CONTENTS.....	2
INTRODUCTION .....	3
Overview.....	3
Features.....	3
Specifications .....	3
INSTALLATION .....	4
Install Control Module.....	4
Install Speaker Box.....	6
OPERATION .....	8
Two-Way System.....	8
Three-Way System.....	8
Operational Check .....	8
Programmable Power-Up Volume Level.....	8
WIRING.....	10
Control Module.....	10
Cables .....	11

## List of Figures

Figure 1. ICA900 Control Module Dimensions .....	5
Figure 2. ICA900 Speaker Box Dimensions.....	7
Figure 3. ICA900 Operation .....	9
Figure 4. ICA900 Control Module Wiring .....	10
Figure 5. ICA900 Cables .....	11

## Overview

The ACT (Always Clear Talking) intercom system from FRC has updated noise cancellation circuitry that essentially eliminates acoustical background noise. The compact control module is separate from the speaker box to provide installation flexibility. Multiple mounting options that only require a two-wire connection between stations, and hands-free remote operation make this intercom especially useful for aerial applications. A high level output signal ensures high quality sound even when the wires are routed through the aerial turntable.

The intercom system is designed to meet rescue and fire service requirements for a voice communications system. It is weather-resistant and specifically designed for outside use on fire service apparatus.

The PTT (Push-To-Talk) station is always in receive mode. The PTT button must be pressed to transmit.

The hands free station is always in transmit mode. To talk on the intercom the operator speaks and the intercom transmits. It will be in receive mode when another station is transmitting.

Since March 2012 all ACT intercom control modules have included a program that allows for setting the volume level at power-up. Two modes are available:

Power-up at the last used volume setting;

Power-up at a pre-set volume.

## Features

Programmable Power-Up Volume Level

Active Noise Cancellation

High Level Output Signal

Hands Free Remote Station (System Option)

## Specifications

Supply Voltage: 12 VDC (24 VDC Option)

Supply Current: 0.5 Amp / Station

Dimensions:

Control Module 5 1/8" by 2 7/8" (w/o Mounting Bracket)

Speaker Box 5 1/8" by 5 1/8" (w/o Mounting Bracket)

---

# INSTALLATION

## Install Control Module

The control module is mounted with a bracket or to the surface with a panel cutout for the connector.

### Bracket Mount

**Note:** The mounting bracket can be removed by unscrewing the adjustment knobs at the side of the control module.

1. Measure and mark mounting location for control module bracket. Refer to Figure 1 for layout and dimensions.
2. Drill two mounting holes (clearance or tapped) for mounting 10-32 hardware.
3. Place mounting bracket in position and secure with two screws.
4. If bracket was removed from module, place module in position and install rubber bushings and mounting knobs.
5. Connect the cables and wiring. Provide enough slack in the cable(s) for the control module to be adjusted as needed. (Refer to Wiring Section).

### Surface Mount

1. Measure and mark mounting location for control module panel cutout and mounting screw holes. Make sure there is clearance behind the panel for the connector and wiring before cutting holes. Refer to Figure 1 for layout and dimensions.
2. Cut out a 1 3/8" wide by 2 3/8" high hole for the connector to fit through and drill two holes (clearance or tapped) for 10-32 mounting screws.
3. Place control module in position and secure with two screws.
4. Connect the cables and wires. (Refer to Wiring Section).

## Bracket Mounted

**Note:** The mounting bracket can be removed by unscrewing the adjustment knobs at the side of the control module. The rubber bushing is installed between the bracket and the control module.

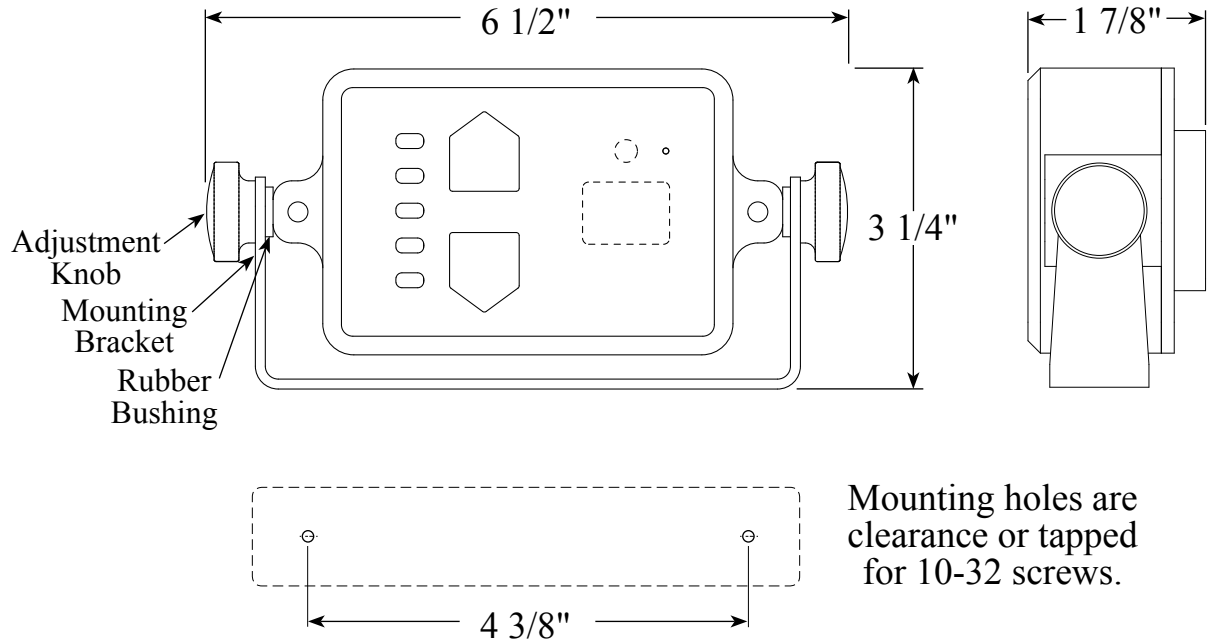

## Surface Mounted

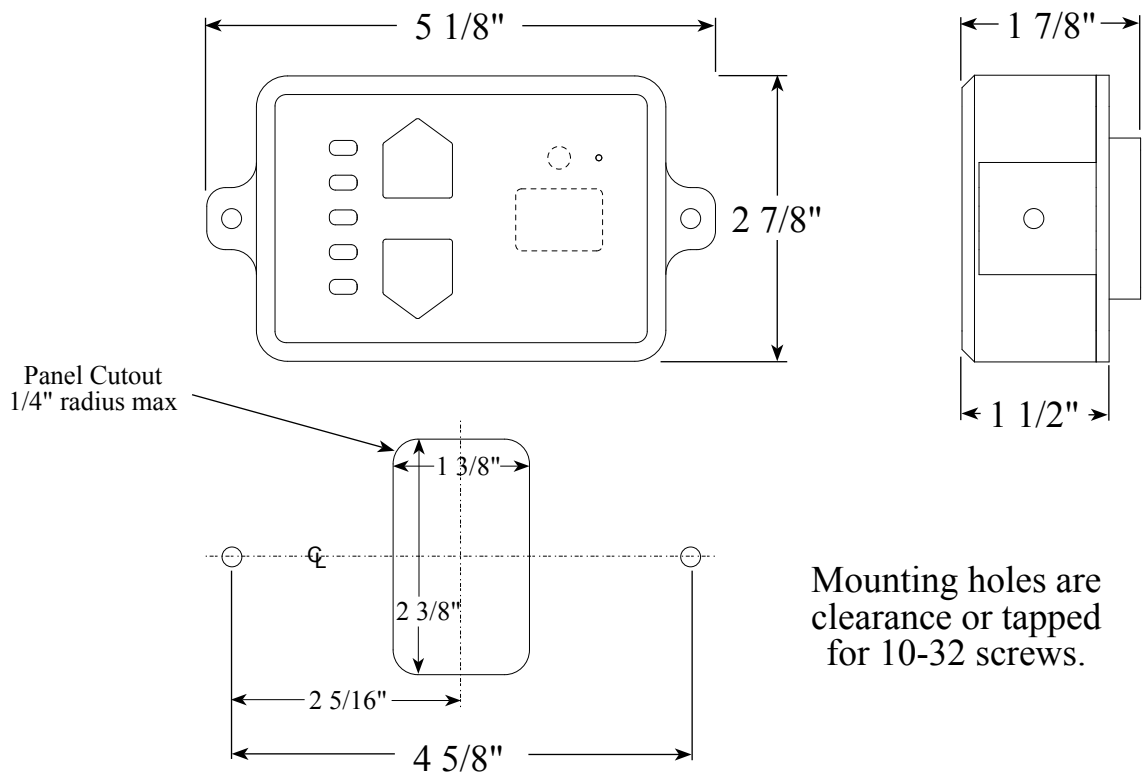

**Figure 1. ICA900 Control Module Dimensions**

## Install Speaker Box

The speaker box is mounted with a bracket or to the surface with a feed through hole for the cable.

### Bracket Mount

**Note:** The mounting bracket can be removed by unscrewing the adjustment knobs at the side of the control module.

1. Measure and mark mounting location for speaker box bracket. Refer to Figure 2 for layout and dimensions.
2. Drill four mounting holes (clearance or tapped) for mounting 10-32 hardware.
3. Place mounting bracket in position and secure with four screws.
4. If bracket was removed from box, place box in position and install rubber bushings and mounting knobs.
5. Connect the cable. Provide enough slack in the cable for the speaker box to be adjusted as needed. (Refer to Wiring Section).

### Surface Mount

**Note:** At the rear of the box there are four 10-32 blind tapped holes to accept the mounting screws (1/2 to 5/8 inch deep). Ensure that the mounting screws do not bottom out in the hole.

1. Measure and mark mounting location for speaker box cable hole and mounting screw holes. Make sure there is clearance behind the panel before drilling holes. Refer to Figure 2 for layout and dimensions.
2. Drill a 3/4" hole for the cable and four clearance holes for 10-32 mounting screws.
3. Place speaker box in position and secure with four screws.
4. Connect the cable to the control module. (Refer to Wiring Section).

## Bracket Mounted

**Note:** The mounting bracket can be removed by unscrewing the adjustment knobs at the side of the speaker box. The rubber bushing is installed between the bracket and the speaker box.

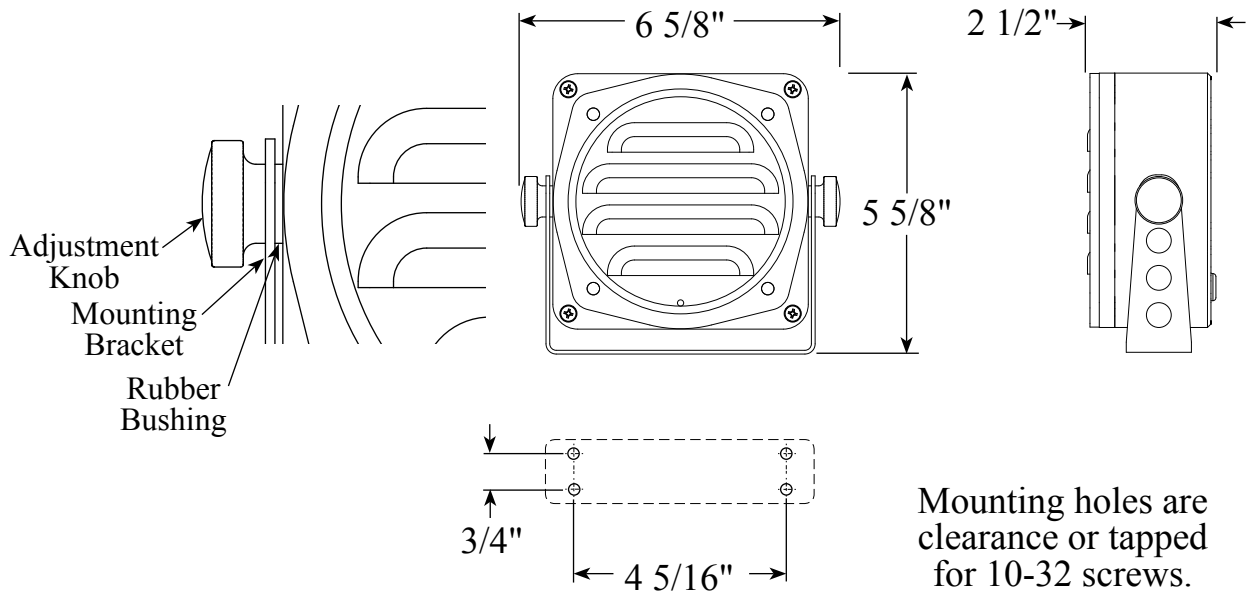

## Surface Mounted

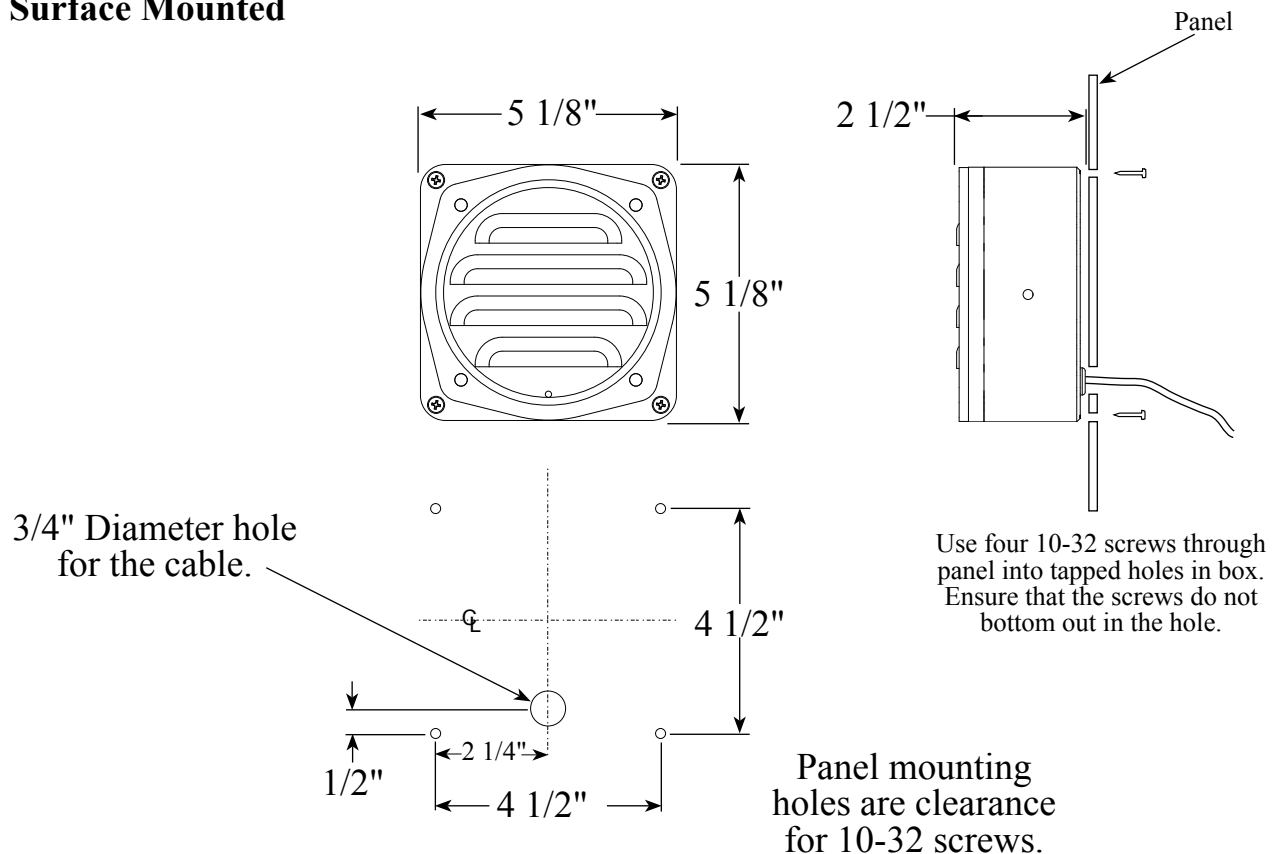

**Figure 2. ICA900 Speaker Box Dimensions**

---

## OPERATION

The Push-To-Talk modules are always in receive mode. The Push-To-Talk button must be pressed to put the module into transmit mode.

The hands free module is always in transmit mode. To talk on the intercom the operator speaks and the intercom transmits. It is in receive mode when another module is transmitting.

### Two-Way System

The system includes two control modules with a Push-To-Talk button or one control module with a Push-To-Talk button and one control module that is hands free.

### Three-Way System

The system includes three control modules with a Push-To-Talk button or two control module with a Push-To-Talk button and one control module that is hands free.

## Operational Check

1. Turn on DC power to intercom.
2. Press the Push-To-Talk button to put control module in transmit mode and speak toward the control module microphone.

Result: Voice is heard over speaker(s) connected to other control modules. (Adjust the volume level buttons at each module for receive level.)

3. Repeat step 2 at each control module. If a hands free module is installed speak toward the control module microphone and it is in transmit mode.

## Programmable Power-Up Volume Level

ACT intercom control modules include a program that allows for setting the volume level at power-up. Two modes are available:

### Power-Up at the Last Used Volume Setting

1. Press and hold the volume increase button until the top LED flashes. Release the button and wait 15 seconds.

Result: The volume drops to 50% level; the module sets to the last used volume level on power-up.

### Power-Up at a Pre-Set Volume.

1. Press and hold the volume decrease button until the bottom LED flashes. Release the button.
2. Press the increase button and set to desired level. Release the button and wait until the highest LED flashes.

Result: The module sets to this volume level on power-up.



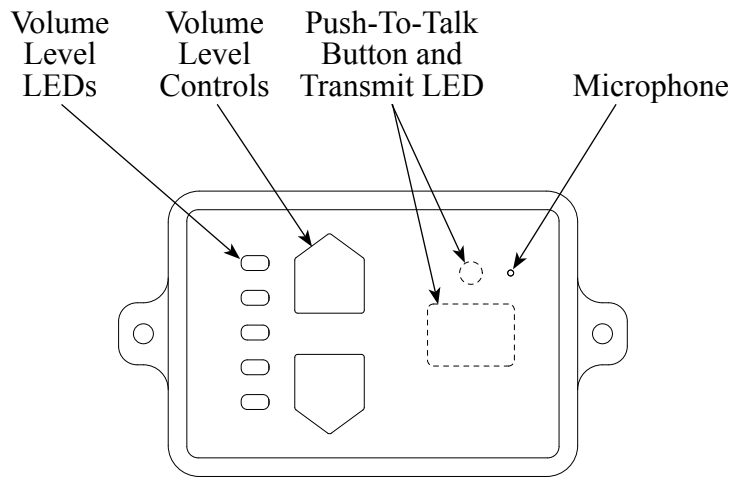

Refer to Wiring Section for detailed information.

### Two-Way System

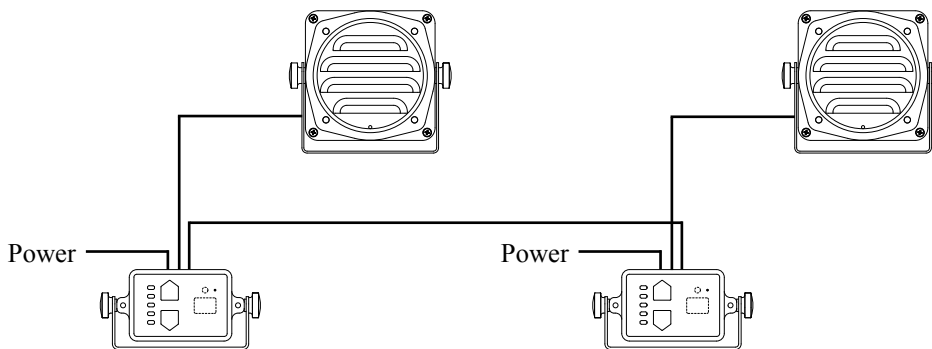

Either control module can be hands free.

### Three-Way System

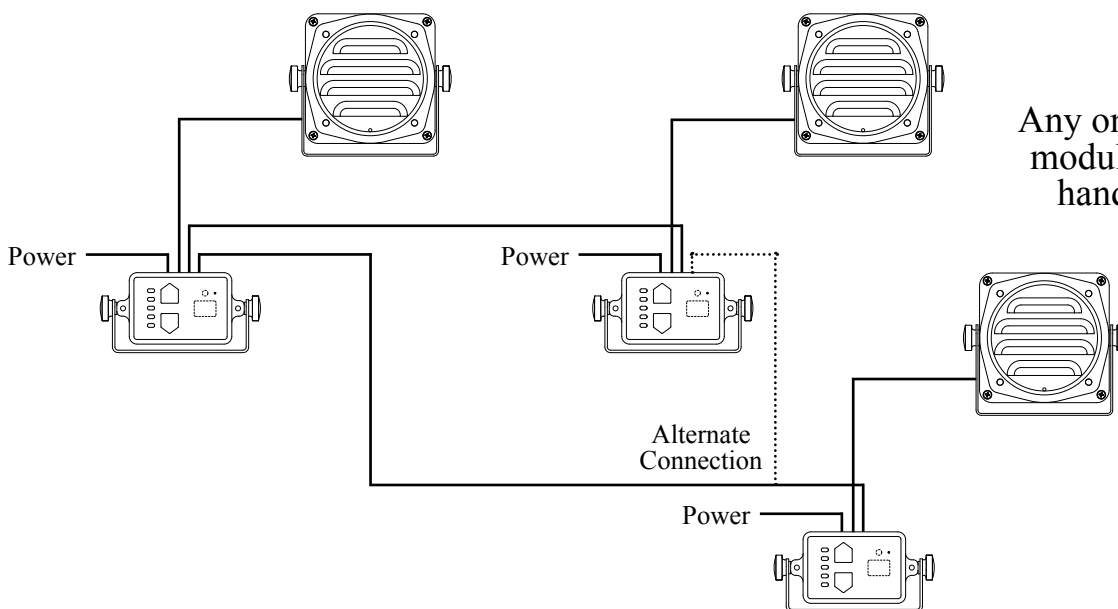

Any one control module can be hands free.

**Figure 3. ICA900 Operation**

## WIRING

The following figures include wiring and cable information.

### Control Module

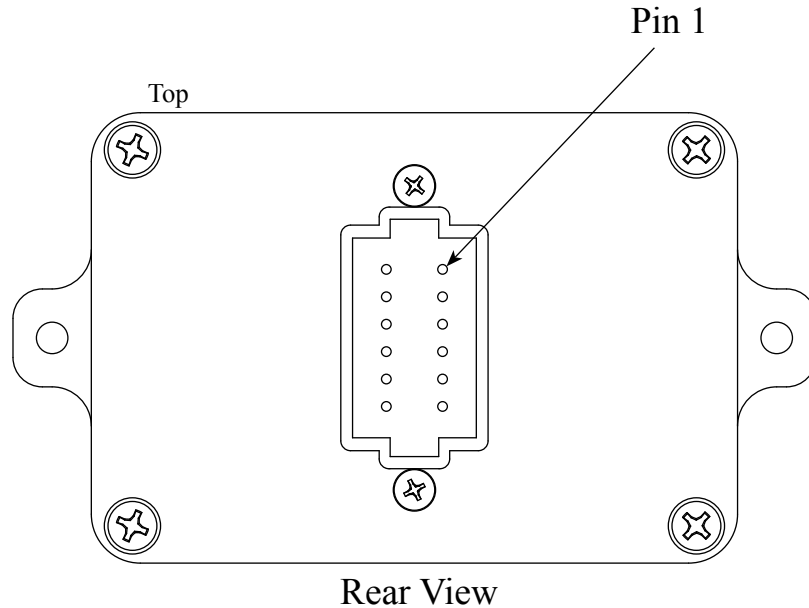

<b>12-Pin Connector/Cable</b>	
<u>Pin/Wire</u>	<u>Description</u>
1/Red	Supply +12(24 VDC)
2/Black	Supply Ground
3/Blue	Speaker
4/Brown	Speaker
5/White	Line 1-A
6/Green	Line 1-B
7/Plug	Line 2-B
8/Plug	Line 2-A
9	Jumper to Pin 10
10	Jumper to Pin 9
11	Jumper to Pin 12
12	Jumper to Pin 11

**Figure 4. ICA900 Control Module Wiring**

# Cables

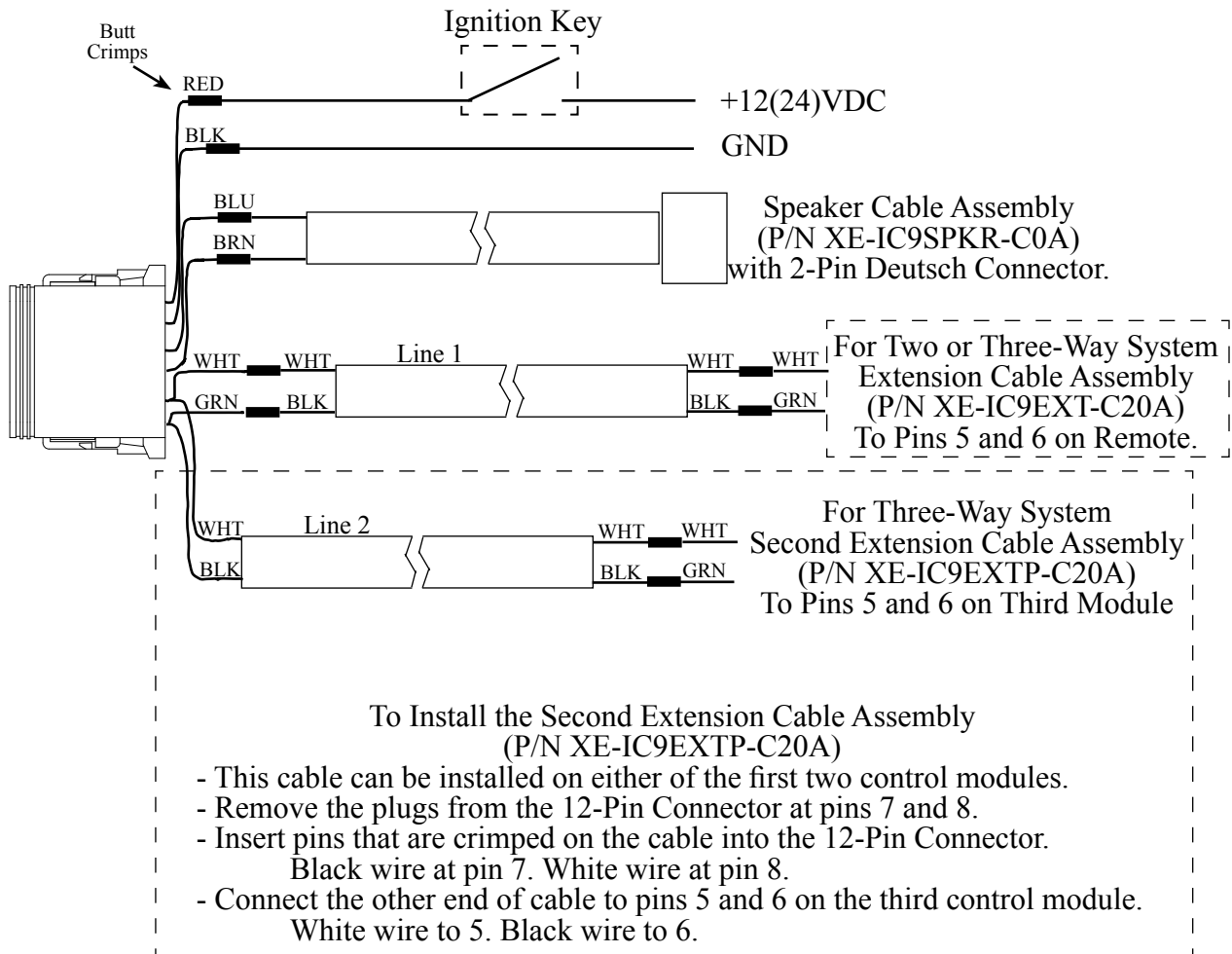

## Notes:

- All cables can be cut to length.
- Speaker cable standard length is 5 feet.
- Extension cable standard lengths are 20 feet (-C20A). Longer cables are available.
- Provide enough slack in the cable when using the mounting bracket for the control module or speaker box to be adjusted as needed.

**Figure 5. ICA900 Cables**