



PRESSURE GOVERNOR, AND ENGINE MONITORING DISPLAY MODEL PBA500



Table of Contents

CONTENTS.....	2	DETAILED MENU INFORMATION.....	26
INTRODUCTION	4	Access Control.....	27
Overview.....	4	Menu Screens.....	27
Features.....	4	Slider Adjustment Screen.....	30
Specifications.....	5	Numeric Adjustment Screen.....	32
		Text / Number Entry Screen.....	33
GENERAL DESCRIPTION.....	6	Set Date / Time Screen.....	35
Components.....	6	Dialog Screen.....	36
Controls and Indicators.....	7	Event Log Readout Screen.....	36
Operator Screen.....	9	Error / Warning Details Screen.....	37
		Operator Diagnostic Screen.....	38
INSTALLATION.....	10		
Install Control Module.....	10	WIRING.....	39
Install Pump 600 PSI Discharge		Connectors and Cables.....	39
Pressure Sensor.....	10	Pressure Sensor.....	41
		Cummins Harness Connections.....	43
OPERATION.....	13	Detroit Diesel Harness Connections.....	44
Controls.....	13	Navistar Harness Connections.....	45
Changing Screen Brightness.....	15	Caterpillar Harness Connections.....	46
Ambient Light Response.....	15	Ford Harness Connections.....	47
Error Codes and Fault Warnings.....	16	Mack Harness Connections.....	50
Pressure Mode Operation.....	17	Scania Harness Connections.....	51
No Discharge Pressure Sensor Detected.....	19	Mercedes Harness Connections.....	53
RPM Mode Operation.....	20	John Deere Harness Connections.....	54
Switching Between Operating Modes.....	21	MAN Harness Connections.....	55
Pump Discharge Pressure is High at Idle Engine.....	21	IVECO Harness Connections.....	56
RPM Limit with Discharge Pressure Less than 100 PSI.....	21	RAM Harness Connections.....	57
Remote Governor Option.....	21	High Idle Wiring.....	59
Preset Settings (Pressure or RPM).....	22		
High Idle.....	22		
Calibrations for Governor.....	23		
Info Center.....	25		

List of Tables

Table 1. Pressure Sensor Output Voltage	5
Table 2. Error Codes and Fault Warnings	16

List of Figures

Figure 1. Controls and Indicators.....	9
Figure 2. Control Module Mounting Dimensions.....	11
Figure 3. Pressure Sensor Dimensions.....	12
Figure 4. PMA500 Rear Connectors.....	39
Figure 5. Pressure Sensor Wiring.....	41
Figure 6. PBA Connector Wiring.....	42
Figure 7. Cummins PBA501 Wiring.....	43
Figure 8. Detroit Diesel PBA502 Wiring.....	44
Figure 9. Navistar PBA504 Wiring.....	45
Figure 10. Caterpillar PBA505 Wiring	46
Figure 11. Ford PBA506 J1939 Translator Module Wiring.....	48
Figure 12. Ford PBA506 PCM Wiring	49
Figure 13. Mack PBA507 Wiring	50
Figure 14. Scania PBA508 Wiring—Type A.....	51
Figure 15. Scania BCI PBA508 Wiring—Type D.....	52
Figure 16. Mercedes PBA510 Wiring.....	53
Figure 17. John Deere PBA516 Wiring	54
Figure 18. MAN PBA524 Wiring.....	55
Figure 19. IVECO PBA526 Wiring.....	56
Figure 20. Dodge Ram PBA528 VSIM Translator Module Wiring	57
Figure 21. Dodge PBA528 PCM Wiring.....	58
Figure 22. High Idle Wiring.....	59

INTRODUCTION

Overview

The pressure governor and all-in-one instrument panel uses state of the art programmable microprocessor technology. It will maintain a steady pump discharge pressure by controlling engine speed or hold a selected engine RPM. It offers complete engine control and remote display in a single compact unit.

The governor operates in one of two modes, pressure or RPM. In pressure mode it maintains a constant pump discharge pressure. The discharge pressure is monitored and compared to the selected pressure setting, the engine RPM is varied to keep the discharge pressure at the selected setting. In RPM mode the governor maintains a constant engine RPM. The pump discharge pressure is monitored and can vary but, as a safety feature it will be limited to an increase of 30 PSI. If the discharge pressure increases 30 PSI or more in the RPM mode, the governor will automatically lower the engine RPM to prevent a high pressure surge.

The panel has a LCD display for engine RPM. There are four radial gauges that provide a constant display of the safe operating ranges for engine coolant temperature, engine oil pressure, battery voltage, and transmission temperature. (For detailed information with the exact numbers and units of measure the MENU button is pressed.) The message display will show pressure and RPM settings; fault and error code information; detailed engine data and program features.

All controls and indicators are located on the front of the control module.

Features

- Automatic Regulation of Pump Discharge Pressure
- Manual Control of Pressure or Engine RPM Settings
- Field Programmable Presets
- Diagnostic Capabilities
- No Pressure or RPM Variation When Changing Modes
- Limits Increase of Pressure When in RPM Mode
- Recognition of No Water Condition With Automatic Response
- Interlock Signal Recognition and Throttle Ready LED
- Return to Engine Idle With the Push of a Button
- Accumulated Engine and Pump Hours
- Display Automatically Adjusted for Day or Night Operation

Specifications

The governor provides the functions, controls, and digital readouts needed for the management of pump discharge pressure.

Control Module

Model Number:	XE-PB500-D0A
Supply Power:	12 VDC (11.8 min, 15.5 max) (Program Option for 24 VDC)
Supply Current:	0.4 A Low Light (Min) - 0.6 A Bright Light (Max)
Dimensions:	3-3/4" Wide by 7-1/4" High by 4" Deep
Unit of Measure:	PSI °F (Program Option for MPa/kPa, Bar, °C)
CANbus Speed:	Engine Driveline J1939 250k/500k auto detect Gov CANbus (FRC) 250K only

Discharge Pressure Sensor

Model Number:	XE-FP4000PT3
Pressure Range:	0 to 600 PSI (0 to 4000 kPa)
Proof Pressure:	1200 PSI
Excitation Voltage:	5 VDC
Output Voltage:	0.5 to 4.75 VDC

Pressure Sensor

	Discharge	Intake
Model Number:	XE-FP4000PT3	XE-IO3100PT3
Pressure Range:	0 - 600 PSI	-30 in/Hg - 600 PSI
Proof Pressure:	1200 PSI	1200 PSI
Excitation Voltage:	5 VDC	5 VDC
Output Voltage:	0.5 - 4.75 VDC (See Table 1)	

Table 1. Pressure Sensor Output Voltage

	0psi	100psi	150psi	200psi	250psi	300psi	600psi
Discharge Sensor XE-FP4000PT3	0.5vdc	1.21vdc	1.56vdc	1.92vdc	2.27vdc	2.625vdc	4.75vdc
Intake Sensor XE-IO3100PT3	0.604vdc	1.295vdc	1.640vdc	1.985vd	2.331vdc	2.667vdc	4.75vdc

GENERAL DESCRIPTION

All controls and indicators are located on the front of the control module.

Components

The pressure governor and engine monitoring display consist of the following components:

Control Module

Discharge Pressure Sensor and Intake Pressure Sensor

Wiring Harness and Extension Cable for Sensors

Control Module

The control module is waterproof and takes up 7-1/2" by 4 inches of panel space. All controls, indicators, and displays are located on the front of the control panel. (Refer to Controls and Indicators.)

Discharge Pressure Sensor

The pressure sensor is mounted on the pump discharge manifold. It provides an input signal to the control module that is proportional to the discharge pressure.

Intake Pressure Sensor

The pressure sensor is mounted on the pump intake manifold. It provides an input signal to the control module that is proportional to the intake pressure.

Audible Alarm Buzzer (User Supplied)

A ground is provided at the 12-pin black connector pin 10 to activate the buzzer (max current: 300mA). The buzzer will sound when a fault code becomes activated. When the Tank Volume indicator drops to 25% the buzzer sounds nine times. (*See Table 2 for the Error Codes and Fault Warnings list/descriptions on page 16.*)

Controls and Indicators

1. Front Bezel / Enclosure
2. Graphic Overlay
2. Display screen
4. Keypad and Indicators
 - (a) 'OK to Pump' – LED indicator
 - (b) 'Throttle Ready' – LED indicator
 - (c) Ambient Light sensor
 - (d) Pressure Control Mode – LED indicator
 - (e) 'RPM' button - selects RPM Control Mode
 - (f) 'PRESSUE' button - selects Pressure Control Mode
 - (g) 'PRESET' Button – recalls /sets pre-programmed setting
 - (h) 'SILENCE' Button – silences audio alarm
 - (i) 'MENU' Button – toggles through actual readings of parameters, opens/closes menu system.
5. Knob Assembly
 - (a) Adjustment Knob – increases / decreases setting
 - (b) 'IDLE' Button – Cancels setting, Sets Engine to Idle RPM

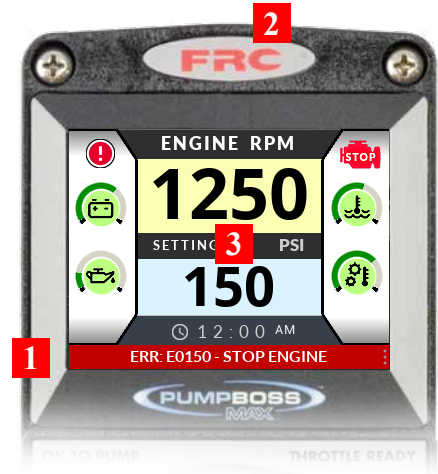

PRESSURE Button

Selects the pressure control mode of operation.

RPM Button

Selects the RPM control mode of operation.

PRESET Button

Press to change/select a pre-programmed value for pressure or RPM setting.

Control Knob

When rotated the control knob changes the pressure or RPM setting. The setting will increase or decrease proportionally to the speed and direction the control knob is rotated.

IDLE Button

When pressed immediately, the Idle button sets the engine RPM to idle. This button can be used in an emergency or for normal shut down after operations. When pressed it will take the governor out of pressure or RPM control mode.

SILENCE Button

Suppresses audio alarms and is used when programming.

MENU Button

Used when accessing detailed information and program features. Detailed information shown includes engine coolant temperature, engine oil pressure, battery voltage, transmission temperature, engine hours, pump hours, and pump discharge pressure. Also shown are the temperature (optional) with the exact measure and units and pump intake pressure (optional).



Figure 1. Controls and Indicators

PRESSURE CONTROL LED

The amber LED is on to indicate operation in the pressure mode.

RPM CONTROL LED

The red LED is on to indicate operation in the RPM mode.

THROTTLE READY LED

This LED will be on when the required interlock conditions are met and the governor is ready to begin operations.

OK to Pump LED

This LED will be on when the required interlock conditions are met and the governor is ready to begin operations.

Light Sensor

Automatically adjusts the displays and LEDs for day or night operations. For day time operations the displays and LEDs are at the brightest. When the amount of light on the sensor drops below a set threshold for more than 10 seconds, the brightness of the display will be dimmed by 25%. The dimmed setting is for night operations.

Operator Screen

Operator screen is displayed after the governor is powered-up and when the governor is controlling the engine. Operator screen contains readouts of: governor status, engine speed, operating parameters and indication and message, should a warning/error condition exist.

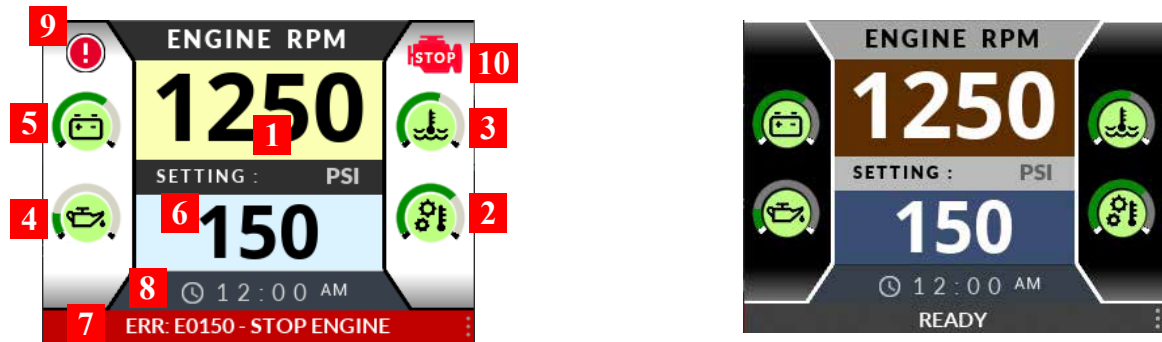

Automatic daytime and nighttime screen modes

Operator Screen Elements

1. Engine RPM – Actual engine RPM
2. Engine Coolant Temperature – Indicator
3. Pump Temperature – Indicator
4. Engine Oil Pressure – Indicator
5. Battery Voltage – Indicator
6. Governor setting display
 - a) Current Setting Value
 - b) Unit of measure
 - c) Setting Label
 - d) Governor Control state or Time
7. Info Center – Parameter Value Read-out (replaces governor setting display when activated)
 - a) Actual value
 - b) Unit of measure
 - c) Label
8. Message bar
9. Warning/Error Indicator
10. Check Engine / Stop Engine Indicator

INSTALLATION

Install Control Module

1. Measure and mark the mounting location for control module cutout and mounting screw holes. Make sure there is clearance behind the panel for the module and cables before cutting holes. (4 3/4" is the minimum clearance needed to be able to remove the connector.) Refer to Figure 2 for layout and dimensions.
2. Drill three holes for mounting screws (#10 mounting hardware is recommended.)
3. Place control module in position and secure with four screws .
4. Connect the cable at rear of the control module. (Refer to Wiring section.)

Install Pump 600 PSI Discharge Pressure Sensor

The discharge pressure sensor is mounted on the discharge manifold of the pump. If there is a check valve in the discharge side of the pump, mount the discharge sensor before the check valve. T-fittings can be used to mount the pressure sensor.

Note: Install the pressure sensor upright so water in the end of the sensor is able to drain back into the pipe.

1. Screw the sensor into a 1/4-18 NPT hole.

Caution: Do not use the main body that houses the electronics to tighten the pressure sensor. Damage to the sensor may occur.

2. Tighten the sensor with a 7/8-inch wrench on the lower hex fitting.
3. Connect the sensor cable. (Refer to Wiring section.)

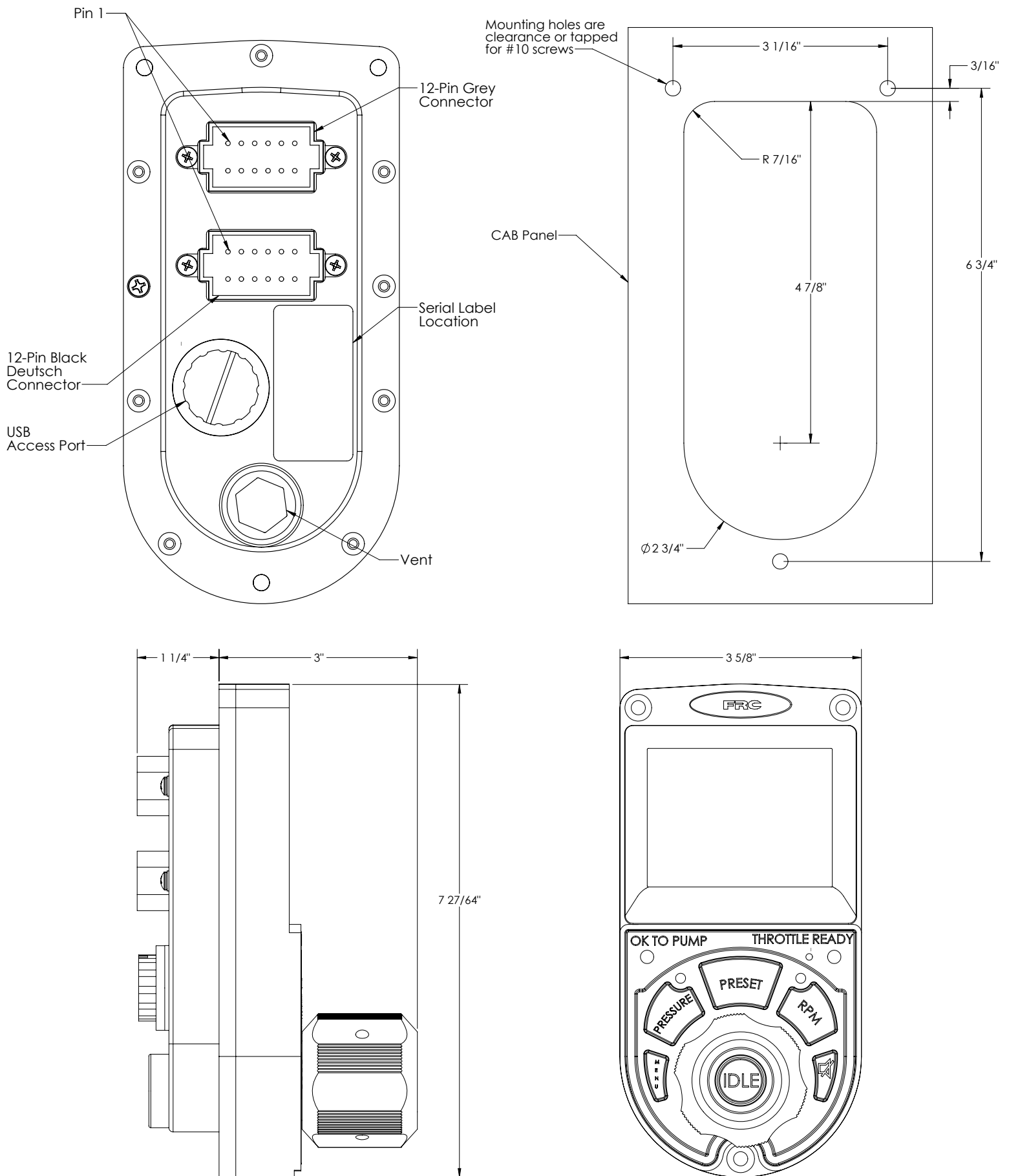
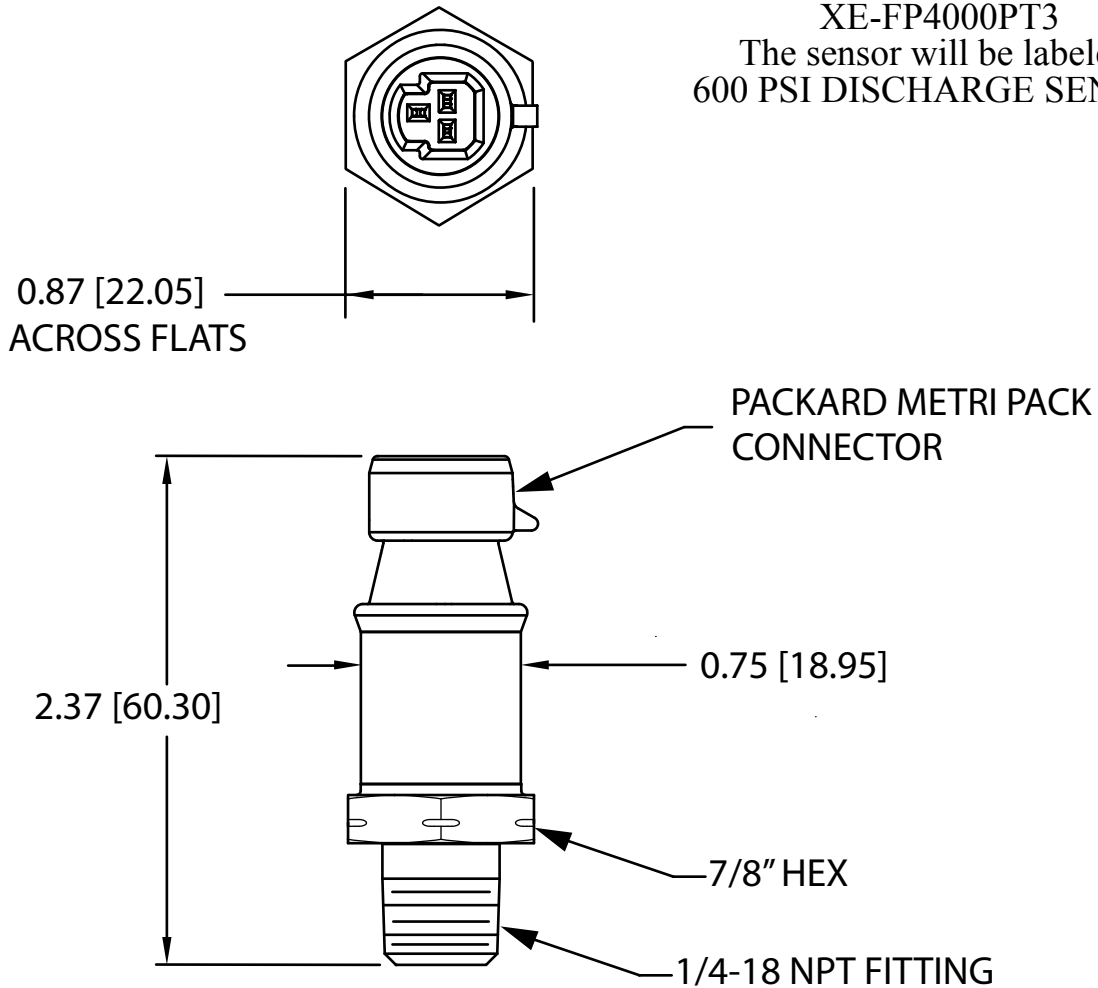

Figure 2. Control Module Mounting Dimensions

The **DISCHARGE** sensor model is:
XE-FP4000PT3
The sensor will be labeled:
600 PSI DISCHARGE SENSOR



inch [mm]

Caution: Do not use the main body that houses the electronics to tighten the sensor. Damage to the sensor may occur.

Figure 3. Pressure Sensor Dimensions

OPERATION

On power-up the governor will be IDLE (no control mode selected). The RPM display will show engine RPM and engine parameters on LCD screen indicating readings with green scale within normal ranges. If any of the parameters exceed safe limits, the display will indicate in RED with associated warning message.

When all necessary throttle enables are active and the interlock circuit is complete the THROTTLE READY LED will light and the governor will be ready to control the engine RPM. Select a control mode to start operations.

When the pump is engaged and the transfer case is locked to the pump shaft, Pump in gear signal will activate 'OK to pump' light. Once the pump is primed and pressure at IDLE RPM exceed 15 PSI, Governor is ready to increase and regulate the pump pressure.

Controls

Knob

The control knob is used to adjust PSI and RPM settings. The governor will sense how fast and in what direction the control knob is rotated and send a signal to the ECM to increase or decrease the engine RPM proportionally.

If the control knob is rotated quickly; the RPM or Pressure setting will change in larger steps.

If the control knob is rotated slowly; the setting will change in smaller increment.

- Rotate the control knob clockwise to increase engine RPM
- Rotate the control knob counterclockwise to decrease engine RPM.

IDLE Button

IDLE button to immediately return the engine to idle. (This will also deselect the control mode.)

PRESSURE Button

Selects the pressure control mode of operation.

RPM Button

Selects the RPM control mode of operation.

MENU Button for Parameter Value Readout

Parameter value readout feature allows an operator to get the exact value of the selected operational parameters of the engine and the governor.

Controls

Parameters readout use:

1. Press and release 'MENU' button
2. Setting display will now show the value and name of one of the available parameters.
3. To switch the displayed parameter, press and release the 'MENU' button several times until the desired parameter is displayed. Parameter selection will loop back to the beginning when the end of the list is reached.
4. Parameter display will turn-off in automatically approx. 8 seconds after the last 'MENU' button press.
5. Governor will immediately turn-off the parameter display when the operator changes a setting by using the knob or 'PRESET' button.

NOTE: Displayed parameters can enabled/disabled by using the built-in 'MENU' system in the 'USER SETTINGS' section.

SILENCE Audio Alarm

This feature allows operator to temporally silence audio alarm. Silencing audio alarm does not cancel warning condition that triggered it.

To silence audio alarm press 'SILENCE' button

PRESET Function

Preset feature is used to store and recall the user programmed setting for each control mode.

Recalling Preset Setting

While the throttle control is enabled, press and release the 'PRESET' button.

The setting window will change to the preset setting. Governor will adjust the engine speed to achieve the new setting.

If the governor is not in throttle ready condition or is in a protected state, recalling a preset will be ignored.

Programming Preset

1. Make sure the governor setting is at IDLE.
2. Use 'PRESSURE' or 'RPM' button to select Control Mode. Programming preset will be for the selected Control Mode only.
3. Press and hold the "PRESET" button. Do not release the 'PRESET' button.
4. When the message indicates 'SET PRESS. PRESET' or 'SET RPM PRESET', the current preset value will be displayed on the setting display.
5. Use the knob to adjust the displayed preset to the desired value.
6. Release the 'PRESET' button to save the new preset value.

NOTE: Presets can also programmed by using the built-in 'MENU' system in the 'USER SETTINGS' section.

Changing Screen Brightness

The primary method to change the screen brightness is to utilize the built-in Menu system. This menu system allows an operator to change all of the relevant screen brightness settings.

As a convenience feature, an operator has the option to temporarily change the current screen brightness without the need to access 'MENU':

To temporarily change current the screen brightness:

1. Press and hold the 'SILENCE' button for at least 5 sec. Do not release the button.
2. When the 'ADJ. SCR. BRIGHTNESS' message is displayed, press and release the 'PRESSURE' or 'RPM' button to decrease or increase screen brightness.
3. Each button press will change brightness setting by 10%. Setting will loop back to 100% or 0%.
4. Release the 'SILENCE' button to stop the screen brightness adjustment.

NOTE: Screen brightness adjustment will automatically time-out in approx. 25 seconds even if the 'SILENCE' button is not released.

NOTE: Screen brightness setting will return to previous setting when the power is cycled. To permanently change the screen brightness, use the 'Menu' system and see the 'DISPLAY' section.

Ambient Light Response

The governor is equipped with a light sensor to measure the amount of ambient light available. Governor uses data from the sensor to determine if it should be in "Day" or "Night" display mode.

By default the unit will switch between DAY or NIGHT display modes as the ambient light changes.

During the change between DAY/NIGHT brightness of the screen back-light will change according to their settings. Additionally, the screen will switch to brighter/darker color palette to assure sunlight visibility or reduce strain during low light operations.

All settings including screen brightness, day/night switch threshold and synchronization of day/night with other devices can be set in the 'MENU'; see 'DISPLAY' section.

Error Codes and Fault Warnings

Table 2.

CODE	TYPE	ON SCREEN MESSAGE (MESSAGE BAR)	DETAILED MESSAGE (ERROR SCREEN)
E0153	ERR	NO PRIMARY CNTL	E0153 - ERROR! Primary Controller not detected! Controller not selected or hardware/wiring issue.
E0154	ERR	PRIM. CNTL. CONFLICT	E0154 - ERROR! Primary Controller conflict! Multiple controllers set as primary. Select primary to reset network.
E0102	ERR	NO ENGINE DATA	E0102 - ERROR! No Engine data! Check wiring. Check ECN settings.
E0103	ERR	NO RPM DATA	E0103 - ERROR! No Engine RPM data!
E0108	ERR	NO TRANS. TEMP. DATA	E0108 - ERROR! No Transmission Temperature Data!
E0104	ERR	NO OIL PRESS. DATA	E0104 - ERROR! No Oil Pressure Data!
E0105	ERR	DISCH. PRESS SENSOR	E0105 - ERROR! Discharge Pressure Sensor Fail! Check sensor. Check wiring.
E0106	ERR	INTAKE PRESS SENSOR	E0106 - ERROR! Intake Pressure Sensor Fail! Check sensor. Check wiring.
E0107	ERR	NO ENG. TEMP. DATA	E0107 - ERROR! No Engine Temperature data!
E0101	ERR	NO DATALINK	E0101 - ERROR! No Datalink.
W0101	WARN	HIGH BATT. VOLT.	W0101 - WARNING! Battery voltage too high!
W0102	WARN	LOW BATT. VOLT.	W0102 - WARNING! Battery voltage too low!
W0103	WARN	HIGH TRANS. TEMP.	W0103 - WARNING! Transmission temperature too high!
W0104	WARN	LOW OIL PRESSURE	W0104 - WARNING! Oil pressure too low!
W0105	WARN	PUMP SENSOR HIGH	W0105 - WARNING! Discharge pressure sensor signal too high!
W0106	WARN	INTAKE SENSOR HIGH	W0106 - WARNING! Intake pressure sensor signal too high!
W0107	WARN	HIGH ENGINE TEMP	W0107 - WARNING! Engine coolant temperature high!
W0108	WARN	NO WATER	W0108 - WARNING! No water!
W0109	WARN	NO ENGINE RESPONSE	W0109 - WARNING! No engine response to control signals.
W0110	WARN	CHECK TRANSMISSION	W0110 - WARNING! Check transmission.
E0150	ERR	STOP ENGINE	E0150 - ERROR! STOP ENGINE! If engine continues to run it will sustain damage!
W0151	WARN	CHECK ENGINE	W0151 - WARNING! Check engine!

Pressure Mode Operation

In the pressure mode of operation the **PRESSURE CONTROL LED** will be on. The governor will maintain a constant discharge pressure within system capabilities. It will adjust the engine RPM automatically to compensate for variations in pressure. In case of a pressure sensor failure, an E0105 error code will flash and the governor will not operate in pressure mode. To pump the operator will have to select the RPM mode.

Note: When changing Control Mode during operations, hold the 'PRESSURE' or 'RPM'

MODE button for 3 seconds.

Note: When changing from RPM mode to pressure mode, the pressure setting will be the pressure in which the pump was operating in during RPM mode.

1. Press 'PRESSURE' button to select the pressure mode.

Result: **PRESSURE CONTROL LED** goes on.

2. Press **PRESET** and/or rotate the control knob to select pressure setting.

Result: Display shows pressure setting, engine RPM changes.

3. Press **IDLE** button after operations to bring engine to idle RPM.

Result: Display shows **IDLE**, **PRESSURE CONTROL LED** goes off, engine at idle RPM.

Opening/Closing Discharge Valves

In pressure mode the governor will maintain the pressure setting regardless of the number of discharge lines that are opened or closed, providing there is a sufficient water supply. As lines are opened, the discharge pressure will start to drop and the governor will raise the engine RPM to maintain the required pressure. As lines are closed, the discharge pressure will start to rise and the governor will lower the engine RPM to maintain the required pressure.

Operating From a Pressurized Supply

When operating from a pressurized water source (hydrant, in-relay, etc.), the intake supply should be routed through a valve. If the pressurized source fails, the pump operator can close the valve. This eliminates the chance of sharp pressure spikes at the pump intake if the supply is resumed suddenly. The operator must open this valve slowly when the supply is resumed to help prevent pressure spikes.

Running Away From Water, Low Water, or No Supply Water

There are situations during pump operations when there may be low or no supply water. This can be due to an empty water tank, a problem on the intake line, air in the pump, changing the water source, or an insufficient water supply.

The governor constantly monitors discharge pressure and compares it to engine RPM. It is programmed to limit RPM increases when conditions arise that fall outside of normal operating parameters.

Running Away From Water: If the discharge pressure starts dropping while operating in pressure mode, the governor increases the engine RPM and attempts to maintain the selected pressure setting. If pressure drops and an increase in RPM does not bring the pressure back up, the governor recognizes this as a running away from water condition. When this condition occurs, the governor switches to the RPM limit mode and controls the engine RPM accordingly.

RPM Limit Mode: When the RPM limit mode is in effect the PRESSURE LED stays on. To alert the operator the RPM LED display flash, and the message display flashes PRESS. LOW RPM LIM. In this mode the pressure setting does not change and the PRESET button is disabled. When the pressure comes back up to the selected pressure setting, the RPM limit mode is canceled and the governor switches to normal operation in pressure mode at the selected pressure.

In some cases the pressure may not come back up but remains at a level above 45 PSI. In the RPM limit mode, the governor behaves like a manual throttle and the operator can raise or lower the engine RPM by rotating the control knob. If the RPM is manually lowered to a point where the pump is not running away from water and pressure is stable, the RPM limit mode is canceled. The governor switches to normal operation in pressure mode with the current discharge pressure as the new pressure setting.

If the engine is set to idle using the IDLE button, the governor comes out of RPM Limit Mode and cancels the pressure setting.

Low Water Cycle: If the discharge pressure is below 45 PSI, but stays above 15 PSI, the governor enters a low water cycle and the message display flashes LOW WATER. It sets the engine at 1100 RPM. If the pressure does not rise above 45 PSI in 7 seconds, the governor sets the engine RPM at idle. The governor repeats the low water cycle as long as the discharge pressure is between 15 and 45 PSI. When the pressure rises above 45 PSI the governor resumes normal operation. (The values for RPM and PSI in the low water cycle are programmable and may vary for some engine/pump combinations.)

No Supply Water: If the discharge pressure is below 15 PSI the engine RPM is set at idle and the message display flashes NO WATER. If, within 3 minutes, the discharge pressure rises above 15 PSI the governor enters the low water cycle. If the discharge pressure does not rise above 15 PSI within 3 minutes, the governor switches to idle mode and cancels the pressure setting. To restart pump operations, the operator must take action (press PRESET and/or rotate control knob to select pressure setting).

No Discharge Pressure Sensor Detected

When the governor does not detect the discharge pressure sensor an error indicator flashes on the screen and ERR: E0105 - DISCH. PRESS SENSOR is displayed in the message display to alert the operator.

Note: If there is no input from the discharge pressure sensor, the governor cannot operate in pressure mode or provide over pressure protection.

If the pressure sensor input is lost during the below operating conditions, the governor functions according to the following scenarios:

Engine is at Idle, Pressure Control Mode Selected

Pressure control mode is disabled and the governor automatically switches to RPM mode.

When operating in RPM mode, the governor cannot provide pressure surge protection with a non-functioning discharge pressure sensor.

Engine is Above Idle, Pressure Control Mode Selected

Pressure control mode is disabled and the governor automatically switches to RPM mode. The RPM setting will be the RPM that the governor was operating at in pressure mode.

When operating in RPM mode, the governor cannot provide pressure surge protection with a non-functioning discharge pressure sensor.

Engine is Above Idle, RPM Control Mode Selected

The operator cannot change to pressure control mode.

When operating in RPM mode, the governor cannot provide pressure surge protection with a non-functioning discharge pressure sensor.

RPM Mode Operation

In the RPM mode of operation the RPM CONTROL LED will be on. The governor will maintain a constant engine RPM.

The pump discharge pressure can vary but, as a safety feature, the governor limits the increase in pressure to 30 PSI over the last established PSI value. As the discharge pressure approaches this limit the governor will automatically lower the RPM to prevent a high pressure surge. The RPM CONTROL LED will blink as the governor sets a lower RPM. This lower RPM will be the new operating RPM setting.

Note: When starting from idle, pressing the 'RPM' button will select the RPM mode. When changing from pressure to RPM mode during operations, hold the 'RPM' button for 3 seconds.

Note: When changing from pressure mode to RPM mode the RPM setting will be the RPM that the pump was operating at in pressure mode.

1. Press 'RPM' button to select RPM mode.

Result: RPM CONTROL LED goes on.

2. Press PRESET and/or rotate the control knob to select RPM setting.

Result: Message display shows RPM setting, engine RPM changes.

3. Press IDLE button after operations to bring engine to idle RPM.

Result: Display shows IDLE, RPM CONTROL LED goes off, engine at idle RPM.

Switching Between Operating Modes

- No variation in discharge pressure or RPM will occur when changing between pressure and RPM modes.
- When changing to RPM mode, the RPM setting will be the RPM that the pump was operating at in pressure mode.
- When changing to pressure mode the pressure setting will be the pressure that the pump was operating at in RPM mode.

When the engine is at idle RPM:

Press the 'PRESSURE' or 'RPM' button and the governor switches modes immediately.

When the engine RPM is above idle:

Press and hold the 'PRESSURE' or 'RPM' button for 3 seconds and the governor changes mode accordingly to button pressed. (This is to avoid an accidental change over if the button gets bumped.)

Pump Discharge Pressure is High at Idle Engine

Once the governor has set the engine to idle, it can do no more to reduce discharge pressures. To reduce discharge pressure the pump operator can gate incoming water, reduce pressure at the intake relief valve, gate discharges, or disable the pump.

RPM Limit with Discharge Pressure Less than 100 PSI

When the pump is operating with a discharge pressure less than 100 PSI RPM is limited to 1500. This RPM limit is programming requires access code. Contact the factory if this limit need to be changed.

Remote Governor Option

The remote governor option duplicates the primary governor functions. The remote governor control module is required to be programmed as a remote If error codes E5 and E6 show on power up, check the programming.

Preset Settings (Pressure or RPM)

The preset button allows the operator to go to a pre-programmed pressure or RPM setting during operations. The setting will be shown in the message display. This procedure is to change the setting in the program.

Note: The engine must be running and the pump engaged interlock circuit must be closed (the THROTTLE READY LED **must be on**). This can also be programmed in User Setting in the System Menus.

1. Press IDLE button.

Result: Engine goes to idle RPM

2. Press 'PRESSURE' or 'RPM' button to select which setting to change.

Result: LED indicator goes on for mode selected.

Note: The message display must show IDLE ENGINE before changing the preset.

3. Press and hold PRESET button. (Continue to hold through step 4.)

Result: Message display shows PRESET after 5 seconds the current setting will flash.

4. Rotate the control knob to change preset setting.

5. Release PRESET button.

Result: The new preset is programmed. Message display shows IDLE.

Note: This can also be programmed in User Setting in the System Menus.

High Idle

The governor programming includes a high idle function. To activate the high idle set interlocks as called for by SOP (normally this would include the transmission in neutral and the parking brake on). Set the High Idle switch to ON.

Note: The pump must NOT be engaged when using the high idle function and the THROTTLE READY LED will be off.

Change High Idle Setting

Note: The high idle is set at 1000 RPM at the factory.

1. With the engine running, set the high idle switch to ON.

2. Press and hold PRESET button for 3 seconds.

Result: Message display will flash the high idle setting.

3. Keep holding the PRESET button and rotate the control knob to set desired RPM.

4. Release PRESET button to store the new high idle setting.

Note: This can also be programmed in Preset/Setup in the System Menus.

Calibrations for Governor

Intake sensor - Set zero point

Intake sensor calibration allows for correction of zero point of intake pressure on the governor. Calibration is performed when sensor is not pressurized (open to atmosphere).

To perform Intake sensor calibration:

- Press and hold MENU button to access menu system
- Select “MAINTANENCE” item and open it by pressing PRESET button
- Select “INTAKE ZERO PT.” item
- Initiate Intake sensor calibration by pressing PRESET
- Display warning dialog: “Make sure your sensor is not pressurized.” will be displayed, press PRESET to proceed

During calibration Governor will measure sensor voltage. Calibration feedback message will be displayed.

“Calibration completed!” message will be displayed if calibration is successful.

“Calibration failed!” message will be displayed if calibration fails

NOTE: Failed calibration indicates sensor output is outside expected range and can be caused by:

Sensor is being pressurized or is exposed to negative pressure

Sensor is defective and should be replaced

Sensor wiring may be disconnected or damaged

Discharge pressure - Set zero point

Discharge sensor calibration allows for correction of zero point of pump discharge pressure on the governor. Calibration is performed when sensor is not pressurized (open to atmosphere). It is recommended for apparatus water pump to be turned off during calibration.

To perform Discharge sensor calibration:

- Press and hold MENU button to access menu system
- Select “MAINTANENCE” item and open it by pressing PRESET button
- Select "DISCHARGE ZERO PT." item
- Initiate Discharge sensor calibration by pressing PRESET
- Display warning dialog: “Make sure your sensor is not pressurized.” will be displayed, press PRESET to proceed

During calibration Governor will measure sensor voltage. Calibration feedback message will be displayed.

“Calibration completed!” message will be displayed if calibration is successful.

“Calibration failed!” message will be displayed if calibration fails

NOTE: Failed calibration indicates sensor output is outside expected range and can be caused by:

Sensor is pressurized, check for residual pressure in manifold and discharges

Sensor is defective and should be replaced

Sensor wiring may be disconnected or damaged

Info Center

The four radial gauges provide a constant display of the safe operating ranges for engine coolant temperature, engine oil pressure, battery voltage, and transmission temperature, they do not show exact numbers or units of measure. This detailed information is shown in the Info Center when the MENU button is pressed. Included with the above, engine hours and pump hours will be shown.

Show Detailed Information

Note: Detailed information is a display only mode and no changes can be made to the data.

The **MENU** button allows the operator to gain access to the detailed information. Each time the **MENU** button is pressed the Info Center display will scroll to show the next.

The Info Center will show the following:

PUMP PRESS. ##### PSI.	(programmable for kPa, MPa or Bar)
INTAKE PRESS. ### -inHg	
BATT. VOLT. ##.# V	
ENG OIL PRESSURE ### PSI	(programmable for kPa or Bar)
ENGINE TEMP. ### °F	(programmable for °C)
ENG TRANS TEMP ### °F	(programmable for °C)
PUMP TRANS TEMP ### °F	(programmable for °C)
ENGINE HOURS ### HR	
PUMP HOURS ### HR	

The Info Center display will revert to normal operation after 20 seconds if no buttons are pressed. When a button other than the **MENU** button is pressed the display will immediately revert to normal operation. To leave the settings unchanged, the **SILENCE** button should be used during operations.

DETAILED MENU INFORMATION

Menu system OVERVIEW

- Post installation device setup
- Setting compatibility with fire apparatus engine ECU and other hardware.
- Adjustment of control defaults, limits, safety features and warnings levels.
- Adjustment of user settings like: presets, preferences and defaults
- Adjustment of user interface data content, format and units of measure.
- Adjustment of integrated displays brightness.
- Provide hardware / firmware configuration and revision information
- Provide diagnostic tools, collect and display diagnostic data.
- Provide tools for firmware updates.

Menu system is a list of the following types of items:

- Adjustable parameters/settings
- Value selection for parameter/setting
- Actions/command that can be executed from the menu
- Readable value, record, message
- Submenu, a group of items that could be any combination of these types

To simplify navigation, all items in the menu system are divided into submenus that group items that are related to each other by function or purpose.

An operator uses keypad buttons or the knob to select the desired item in the menu or submenu. By pressing a designated button(s) in the menu, the system will respond with action according to the selected item type.

Response may be:

- Open submenu
- Return to previous submenu
- Open screen to adjust parameter value
- Change value of parameter to selected value
- Execute command, action or initiate process
- Display dialog box with additional information

Access Control

The menu system employs the user access control. The content of all menus and submenus is adjusted based on the currently set user access level. All menu items have an individually defined access level. If the menu item access level setting is higher than the current user level, the item will not be displayed in the menu.

Privileged user level can be set by entering a code in the “ACCESS” submenu.

The following user levels available are:

0: - Operator – default, and does not require a code. Settings are available to anyone that has access to the governor.

1: - OEM, installer, service – privileged user, protected with an OEM code. This is not available to an operator.

2: - Factory – Governor manufacturer protected with Factory code. Items are not available to users with access level 0 and 1.

To restore the default user level, use the item ‘LOGOUT’ (action) of the ‘ACCESS’ sub-menu or cycle the supply power.

Menu Screens

Menu system utilizes several screens to perform all of its functions:

1. Menu list
2. Slider adjustment screen
3. Numeric adjustment screen
4. Text / Number entry screen
5. Set date time screen
6. Dialog screen
7. Log entry screen
8. Error/warning detail screen

Menu List Screen

Menu List screen is used to display list of menu or submenu items as shown on examples below:

NOTE: MENU button (Orange) has two functions.

1. Access Menu (hold Menu button for 2 secs)

Access to Menu is NOT allowed while governor is controlling apparatus engine. Engine must be at true Idle.*

2. Activate and toggle information in Info Center

*If Idle RPM CNTL or Idle Press CNTL options are active Interlock I-Pump and Pump Clutch Engaged must be disengage to access Menu.

1. Header bar

- (a) Icon
- (b) Title / Parameter Name
- (c) Privileged User Indicator (when active)

2. Item list – number of items

Each item contains:

- (a) Item Icon – icon representing type Or state of the item (), [] not selected, selected (O), [V] selected
- (b) Item Title / Name or Selectable Value
- (c) Item Current value (optional)

3. Footer bar has a button with function hints.

Button image will be accompanied with icon, which depicts an image of the button function for the selected item. Button(s) that do not have a function for a selected item will be hidden.



4. Menu List Scroll indicators (optional) – if a menu item list exceeds screen capacity, an indicator with arrow(s) will appear:

(a) at the bottom of the list, if there are more items below the last item displayed on the screen

(b) at the top of list, if there are more items above the first item displayed on the screen

5. Selection position indicator. Vertical bar indicates the relative location of the currently selected item within whole menu list.

6. Press the SILENCE button when the program (C) code is flashing to exit.

EXAMPLES: Menu List Values list Checkbox parameters

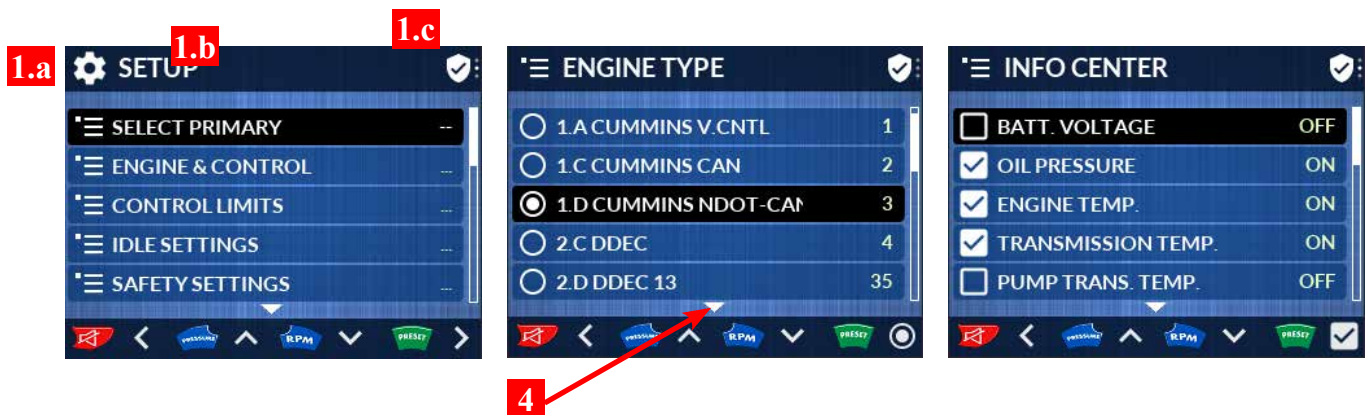

Using Menu List Screen

Use the 'RPM' or 'PRESSURE' button to select and change selected item. With each press, the selection will advance to the next item ('RPM' button), previous item ('PRESSURE' button). When the end of the list is reached, the selection will loop back to the first item after 'RPM' button is pressed. When first item is selected, list will loop back to the end after 'PRESSURE' button is pressed.

Alternatively: Rotate knob to change the selected item. By default, clockwise rotation will select the next item, and counterclockwise will select the previous item. Rotate the knob rapidly to move quickly through long lists.

Acting on Selected Menu Item:

Use the 'PRESET' button to take default action for selected item.

Alternatively: Press the 'IDLE' button in the center of the knob to do the same.

Default action could be:

- Open submenu
- Open adjustment screen if selected is adjustable parameter
- Open list of values if selected is parameter is set by list of selectable values
- Change parameter value to a value selected from the list
- Switch parameter ON [x], or OFF [], for checkbox item
- Initiate command or action (like: read log file, reset to factory settings, etc.)
- Start process (like: start calibration)
- Display dialog to prompt user input
- Display details of event log item
- Display details of error / warning

Return to previous menu:

Use 'SILENCE' button to cancel action and return to previous menu.

Slider Adjustment Screen

Slider adjustment screen is used to set the value of parameter within a range usually between 0 and 100.

If a parameter has an additional adjustment limit, it will be represented by the gray area on the slider and adjustment will be restricted within that range.

EXAMPLE: Day / Night mode switching threshold 0-100%

Day/Night Threshold:

Day/Night Threshold setting determines the level of ambient light required to switch day/night mode. The higher the setting, the more ambient light is required to switch to day mode. The lower the setting, the less ambient light is required to switch modes.

Elements of Slider Adjustment Screen:

1. Header bar
 - (a) Icon
 - (b) Parameter Name
2. Slider control – slider representing current value of parameter
3. ‘Save/Return’ control – control to save new value and return to previous menu or cancel changes and return to previous menu
4. Footer bar will have button function hints. Button image will be accompanied with an icon, which depicts an image of the button function for the selected item.



Using Slider Adjustment Screen

Selecting Control on the Screen:

Use the 'RPM' or 'PRESSURE' button to select/change active control on the screen. Alternatively: Rotate knob to change selected item.

Changing Value:

Select Slider control.

Use the ‘PRESET’ button to move the slider to the right, to increase the value. Or, use the ‘SILENCE’ button to move the slider to the left, to decrease the value.

Alternatively: Press the ‘IDLE’ button to switch the knob function to adjust the value, and the slider and its value will change color to yellow. Rotate the knob to change the value. Clockwise rotation will increase the value, counterclockwise will decrease the value. When finished, press the ‘IDLE’ button to turn off knob adjustments.

Saving New Value:

Select ‘Save/Return’ control

Press the ‘PRESET’ button to save the new value and return to the previous menu.

OR Press the ‘SILENCE’ button to cancel the change and return to the previous menu.

Numeric Adjustment Screen

The Numeric Adjustment screen is used to set the value of parameters within a predefined numeric range.

The current Parameter Value is displayed when the screen is loaded. This value will be expressed in the unit of measure, which was set to be used by the governor. Unit of measure is indicated on the screen.

EXAMPLE: RPM Preset value [RPM]

Elements of Numeric Adjustment Screen:

1. Header bar
 - (a) Icon
 - (b) Parameter Name
2. Parameter value control with unit of measure information – used to change the value
3. Reset control – used to reset setting to initial value
4. ‘Save/Return’ control – to save the new value and return to the previous menu or cancel changes and return to previous menu
5. Footer bar will have button function hints. Button image will be accompanied with an icon, which depicts an image of the button function for the selected item.



Using Numeric Adjustment Screen

Selecting Control on the screen:

Use 'RPM' or 'PRESSURE' button to select/change active control on the screen.

Alternatively: Rotate Knob to change selected item.

Changing value:

Select Parameter Value control.

Use ‘PRESET’ button increase value, or use ‘SILENCE’ button to decrease value. Holding button down will make value change advance automatically with larger steps.

Alternatively: Press ‘IDLE’ button to switch knob function to value adjustment, value will change the color to yellow. Rotate the knob to change the value.

Clockwise rotation will increase value, and counterclockwise will decrease the value. When finished, press the ‘IDLE’ button to turn off the knob adjustment.

Restoring Initial Value:

Select Reset control.

Use the 'PRESET' button return to the initial value.

Saving New Value:

Select 'Save/Return' control

Press the 'PRESET' button to save new value and return to the previous menu.

OR Press the 'SILENCE' button to cancel the change and return to the previous menu.

Text / Number Entry Screen

Text / Number Entry screen is used to enter the text or number of a predefined length, character by character.

Current Text/Number will be displayed when screen is loaded, (this does not apply to the access code).

EXAMPLE: User access code (numeric)

Elements of Text / Number Entry Screen:

1. Header bar
 - (a) Icon
 - (b) Parameter Name
2. Value control – used to change value
3. Clear control – used to clear all characters in the value field
4. 'Save/Return' control – to save new value and return to the previous menu or cancel changes and return to the previous menu
5. Footer bar will have button function hints. Button image will be accompanied with an icon, which depicts an image of the button function for the selected item.

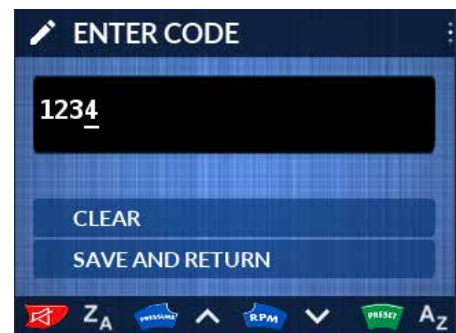

Text / Number Entry Screen

Selecting Control or Character to change on the screen:

Use the 'RPM' or 'PRESSURE' button to select/change the active control on the screen. If the selected control is the Value Control, press the 'RPM' button. This will move the cursor to next character in that field until end is reached. Then it will select next control on the screen. When Value Control is selected press the 'PRESSURE' button. This will move the cursor to previous character in that field until first character is reached. Then it will loop back to previous control on the screen.

Alternatively: Rotate knob to change selected control or character within the value control.

Changing the Value:

Select the Parameter Value control. Use 'RPM' or 'PRESSURE' button or knob to move the cursor to the character/numeral to be changed.

Use 'PRESET' button advance to next letter/numeral in selected position, or use 'SILENCE' button to go back to the previous letter/numeral in the selected position. Holding down the button will make the letters/numbers change automatically.

Alternatively: Press 'IDLE' button to switch knob function to value adjustment, and the value will change the color to yellow. Rotate the knob to change the value. Clockwise rotation will increase the value, and counterclockwise will decrease the value. When finished, press the 'IDLE' button to turn off the knob adjustment.

Clearing Value Field:

Select Clear control.

Use the 'PRESET' button return to clear the value field.

Saving New Value:

Select 'Save/Return' control

Press the 'PRESET' button to save the new value and return to the previous menu.

OR Press the 'SILENCE' button to cancel the change and return to the previous menu.

Set Date / Time Screen

Set the date/time screen is used to set the date and time according to the governor's internal clock. Date and time format will be set according to the date and clock formats as set in the menu.

EXAMPLE: Date Time set screen

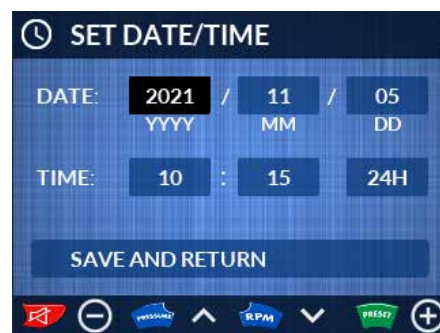

Elements of Set Date/Time screen:

1. Header bar
 - (a) Icon
 - (b) Parameter Name
2. Year control
3. Month control
4. Day control
5. Hour control
6. Minutes control
7. AM / PM or 24H control
8. 'Save/Return' control – to set date / time.
9. Footer bar will have button function hints. Button image will be accompanied with an icon, which depicts an image of the button function for the selected item.

Using Date / Time Screen**Selecting Control on the Screen:**

Use 'RPM' or 'PRESSURE' button to select/change the active control on the screen.

Alternatively: Rotate knob to change the selected item.

Changing the Value:

Select the control.

Use the 'PRESET' button to increase the value, or use the 'SILENCE' button to decrease the value. Holding down button will make the value advance automatically.

Alternatively: Press 'IDLE' button to switch knob function to value adjustment, value will change the color to yellow. Rotate the knob to change the value. When finished, press the 'IDLE' button to turn off knob adjustment.

Set New Date/Time:

Select the 'Save/Return' control

Press the 'PRESET' button to set the date/time and return to the previous menu.

OR Press the 'SILENCE' button to cancel the change and return to the previous menu.

Dialog Screen

Dialog screen is used to display messages to the user to:

- inform user that certain action will take place or is in process
- inform user of result of action / command upon its' completion or failure
- warn user of risks of taking some actions
- get user response, confirmation or cancellation before action is taken

Dialog screen header color changes depending on type of information that is displayed.

*EXAMPLE: Warning before factory defaults are restored.
Requests user confirmation or cancellation*

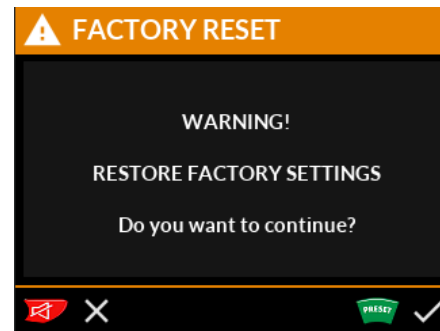

Elements of Dialog screen:

1. Header bar
 - (a) Icon
 - (b) Message Title
2. Message
3. Footer bar will have button function hints. Button image will be accompanied with an icon, which depicts an image of the button function for the selected item.

Use of Dialog Screen

Use the 'PRESET' button to agree to request, proceed with an action or acknowledge message and close the dialog screen.

Use the 'SILENCE' button to cancel a request, stop action or acknowledge message and close the dialog screen.

Note: Some dialog screens may have only one action that the user can take, or no action at all. Dialogs with no action will time-out automatically, or change when the process or action has been completed.

Event Log Readout Screen

Event Log readout screen is used to display the entries from a current or previous event log file.

EXAMPLE: Current Log File Entry;

Entry number 12 out of 12

Recorded on Nov 5th 2021 at 10:15

Entry: System setting changed

Governor RPM Preset was set to new value of 1120

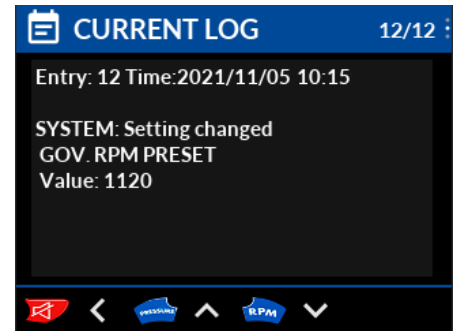

Elements of Dialog screen:

1. Header bar
 - (a) Icon
 - (b) Log File Name Opened
2. Log Entry Information
3. Footer bar with button function hints.

Using Event Log Readout

Use the 'RPM' or 'PRESSURE' button to move to the next or previous entry in an open event log.

Alternatively: Rotate Knob to move to next entry (clockwise) or previous entry (counterclockwise).

Use the 'SILENCE' button to close the Entry Log and return to the previous menu.

Error/Warning Details Screen

The Error/Warning Details screen is used to display information on currently active error/warnings. A list of active Errors/Warnings can be found in the 'ACTIVE WARN./ERR.' submenu.

EXAMPLE: Warning W0105

Active warning, issue 2 out of 3

Code: W0114

Type: Warning

Message: Pump Transmission Temperature high

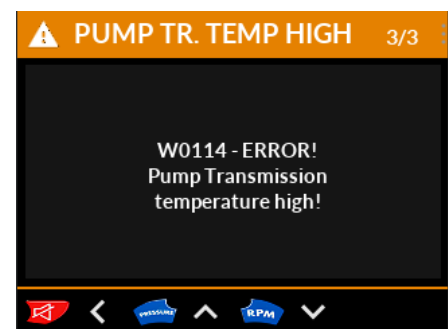

Elements of Error/Warning screen:

1. Header bar
 - (a) Icon
 - (b) Error/Warning Name
2. Error Warning details
3. Footer bar with button function hints

Using Error Warning detail screen

Use the 'RPM' or 'PRESSURE' button to move to the next or previous active error/warning if available.

Alternatively: Rotate the knob to move to the next active err/warning (clockwise) or previous error/warning (counterclockwise) if they exist.

Use the 'SILENCE' button to close the screen and return to the previous menu.

Operator Diagnostic Screen

The Diagnostic Screen is a tool to aid in troubleshooting issues with Governor Setup or hardware. Diagnostic Screen can be enabled to allow operator to observe the actual values of all parameters of governor and engine in one place while in operation.

The screen can be enabled in the 'DIAGNOSTIC' submenu. The screen will remain active until it has been disabled or power has been recycled.

EXAMPLE: Diagnostic Screens

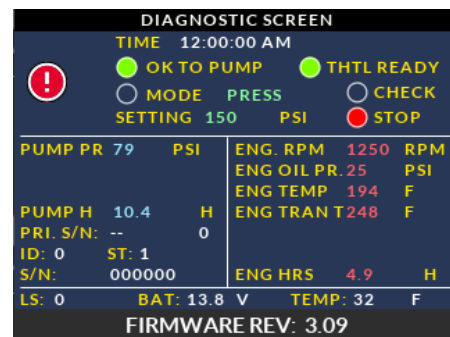

Using Diagnostic screen

Enable Diagnostic Screen in the menu. Close the Menu. Diagnostic screen will now replace the regular operator screen.

Operation of the governor can be conducted in a regular manner using the buttons or knob.

Press and release the 'MENU' button to toggle the display readout between the actual readings to the sensor signal voltage where available.

To end, using the Diagnostic Screen, go to the Menu 'DIAGNOSTIC' and disable the Diagnostic Screen or cycle power to the Governor

WIRING

The following figures include the schematics, wiring diagrams, block diagrams, and cables.

Connectors and Cables

For most engines the governor receives engine RPM, oil pressure, and coolant temperature data over the J1939 data link from the engine ECM. Some engines do not broadcast this data over the data link and sensors may need to be installed.

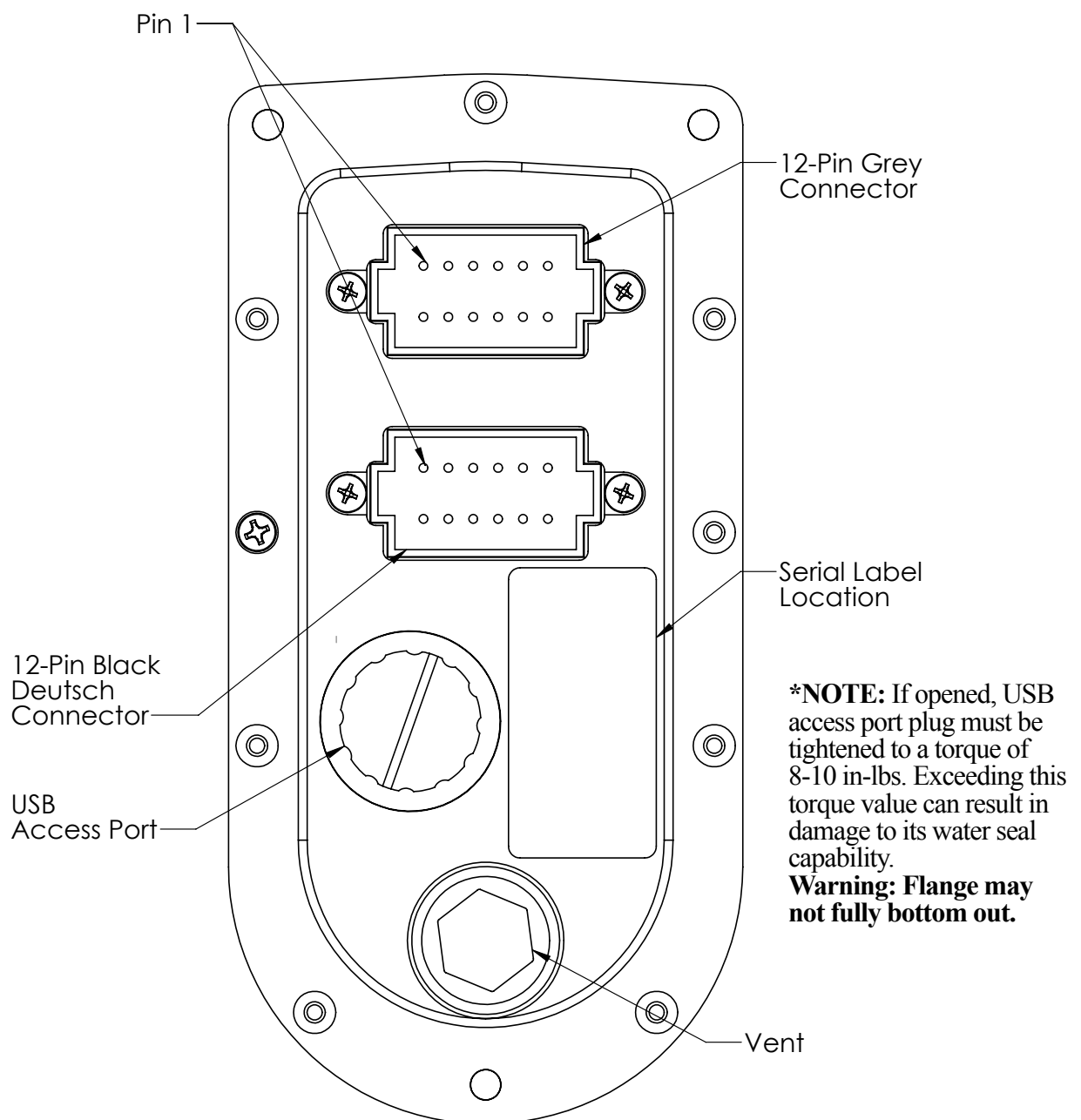

Figure 4. PMA500 Rear Connectors

12 PIN GRAY DEUTSCH RECEPTACLE

<u>PIN</u>	<u>COLOR</u>	<u>DESCRIPTION</u>
1	Red	Supply Power (12/24 VDC)
2	Black	Ground
3	White	Interlock (Throttle Ready Battery input)
4	Yellow	Engine J1939 CAN (H)
5	Green	Engine J1939 CAN (L)
6	RED	Discharge Pressure Sensor +5V
7	Black	Discharge Pressure Sensor GND
8	White	Discharge Pressure Sensor Signal input
9	Red	Intake Pressure Sensor +5V
10	Black	Intake Pressure Sensor GND
11	White	Intake Pressure Sensor Signal input
12	Gray	Engine J1939 CAN Shield

12 PIN BLACK DEUTSCH RECEPTACLE

<u>PIN</u>	<u>COLOR</u>	<u>DESCRIPTION</u>
1	Orange	Remote throttle +5 VDC Reference from ECM
2	Black	Remote throttle Signal Return from ECM
3	White	Remote throttle Signal to ECM (Voltage only)
4	Purple	High Idle Active Input (+ VDC) (Battery input)
5		FRC CAN (L)
6		FRC CAN (H)
7		FRC CAN (Shield)
8	Blue	Remote throttle enable output (IVS)
9		Spare (N/A)
10	Brown	Buzzer output (Low active)
11	White	Pump Clutch Engaged (Pump in Gear)
12		Spare (N/A)

***NOTE:** Not all wires are used for all engines. Refer to the engine specific wiring diagram for interface connections.

Pressure Sensor

Pressure Sensor Cable
from 40-Pin Connector

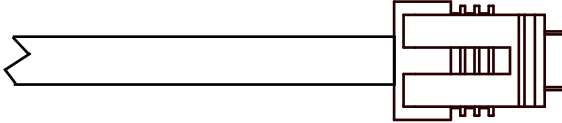

Pressure Sensor Cable 3-Pin Connector

Pin/Wire	Description
A/Black	Ground
B/Red	Supply Voltage
C/White	Signal

Pressure Sensor
Top View

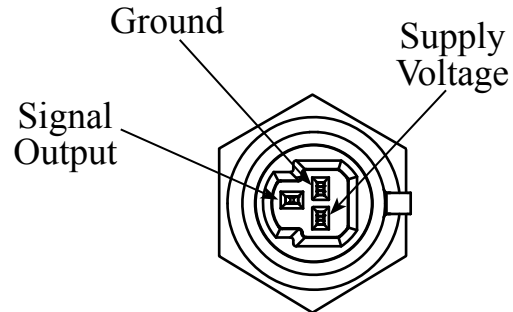

Pressure Sensor
Side View

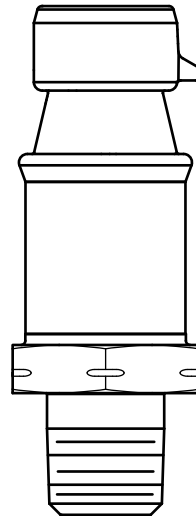
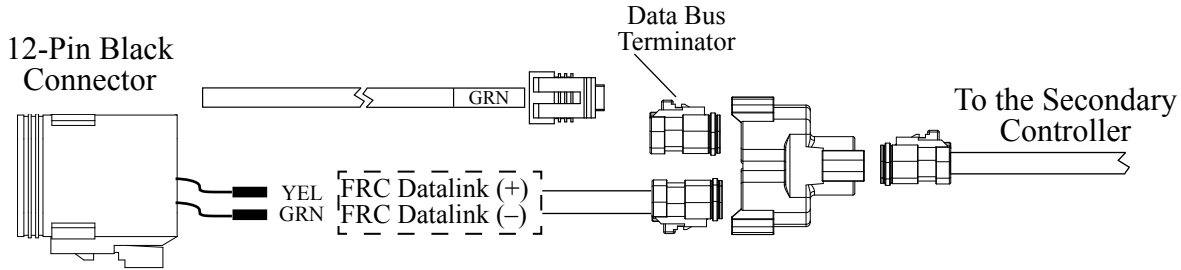

Figure 5. Pressure Sensor Wiring



Secondary Controller, Cables and Connections

Secondary Controller

Note: The unit must be set to REMOTE on the Secondary Controller control module.

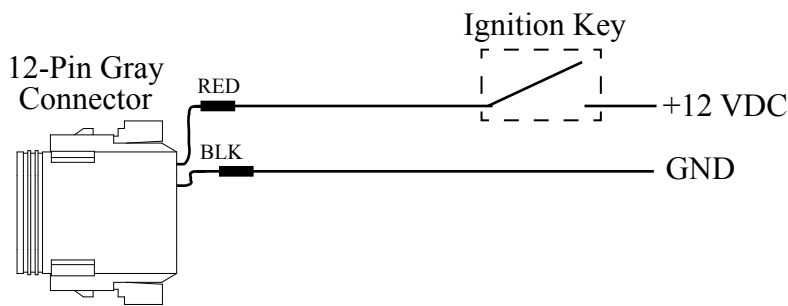
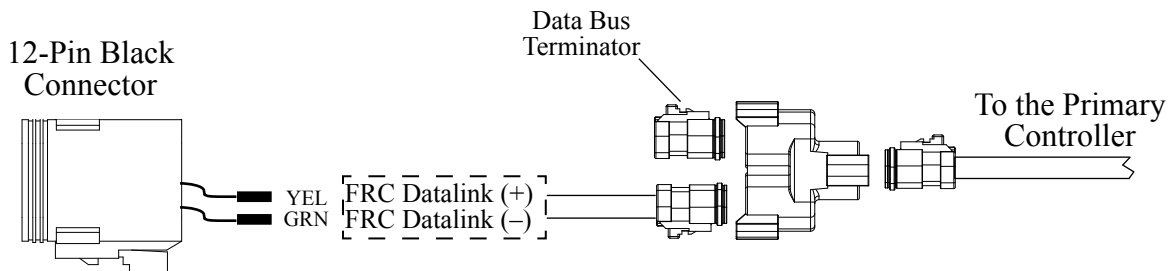

NOTE: Terminating resistor and adapters are included in the kit for connection to the primary display; no other wires are required for remote operation.

Figure 6. PBA Connector Wiring

Cummins Harness Connections

Interface Information

For use on 2004 or newer engines.

The governor is designed to control engine throttle directly over the SAE J1939 databus.

If the PUMPBOSS is being used on a COMMERCIAL CHASSIS with a Cummins Engine, ENSURE that the Cummins Engine EMERGENCY VEHICLE CALIBRATION is programmed in the engine ECM for the PUMPBOSS to work.

Note: Refer to Figure 4. PBA Connector Wiring for power and interlock wire connections.

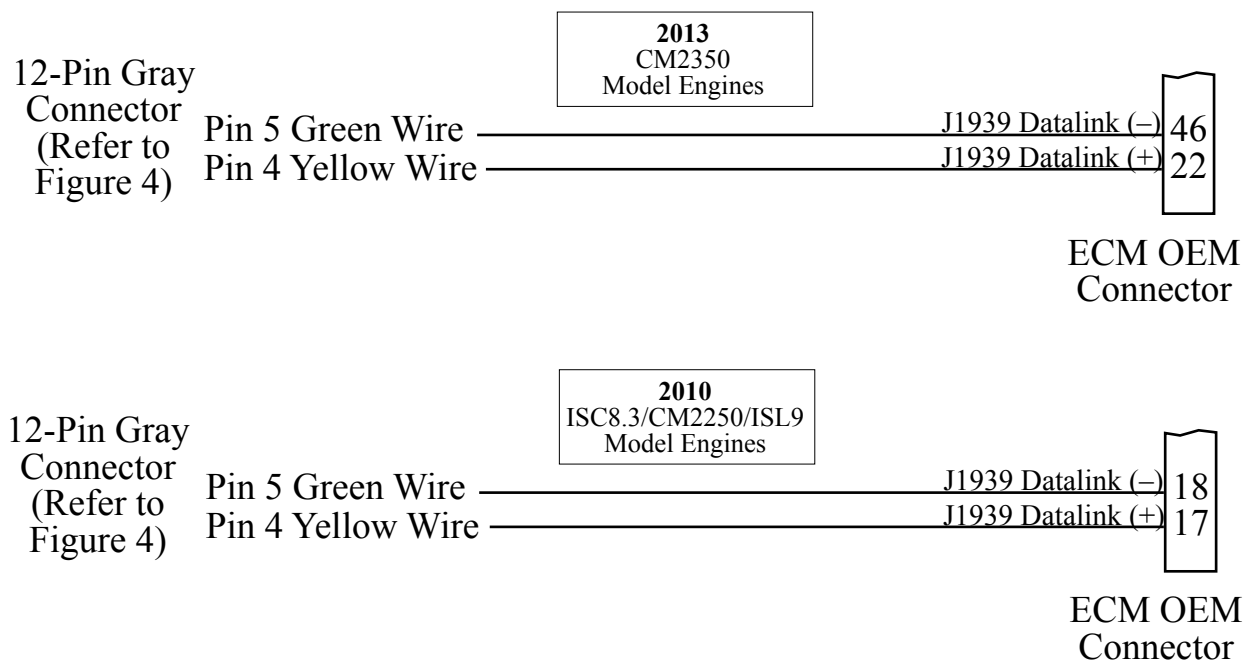

Figure 7. Cummins PBA501 Wiring

Detroit Diesel Harness Connections

Interface Information.

The governor is designed to control engine throttle directly over the SAE J1939 databus. Remote throttle does not need to be enabled in the ECM.

Note: Refer to Figure 4. PBA Connector Wiring for power and interlock connections.

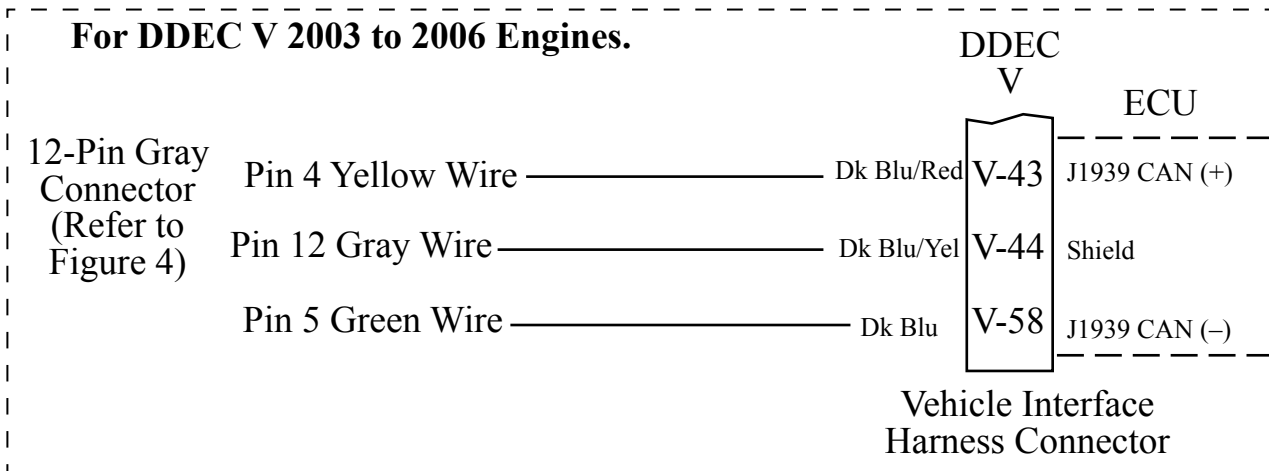
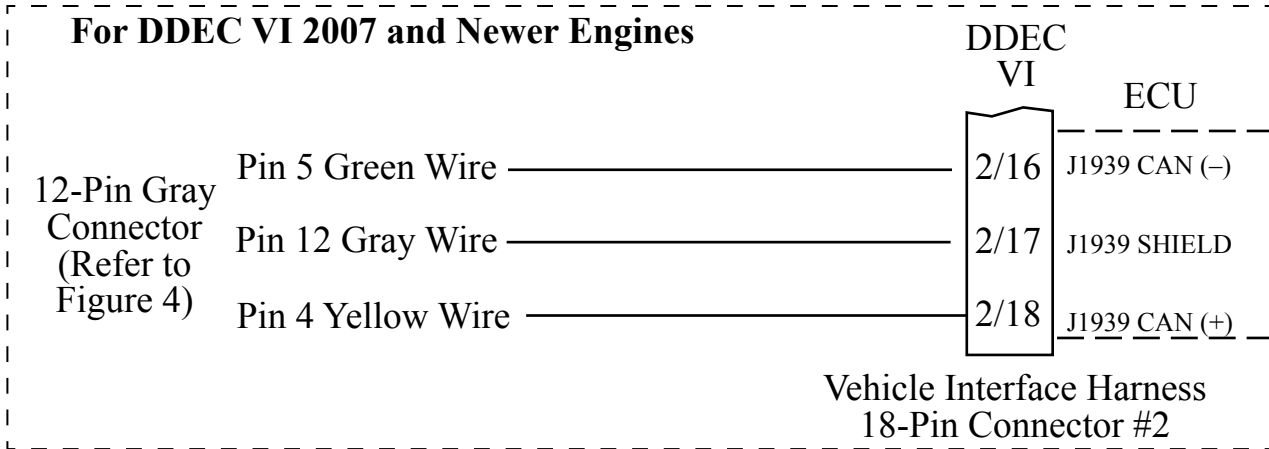

Figure 8. Detroit Diesel PBA502 Wiring

Navistar Harness Connections

Interface Information

The ECM must be programmed for remote variable throttle operation.

Note: Check the governor engine code to verify the program setting (for J1939 control use 4C and for voltage control use 4D). Wire accordingly or change the code.

Note: Refer to Figure 4. PBA Connector Wiring for power and interlock wire connections.

J1939 CAN Bus Control 12VXY 2010 and Newer MAXXFORCE 11 and 13 Engines

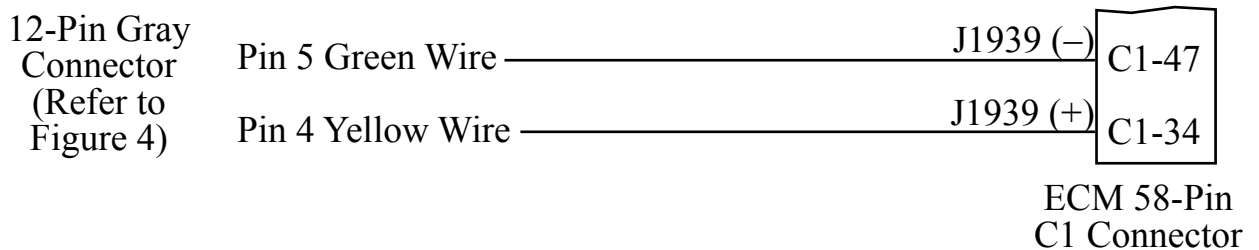

Voltage Control Post 2007 MAXXFORCE 7, DT, 9, 10, 11, and 13 Engines

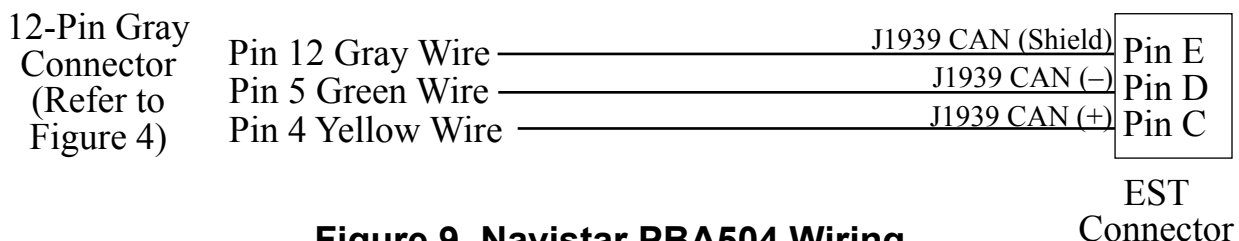
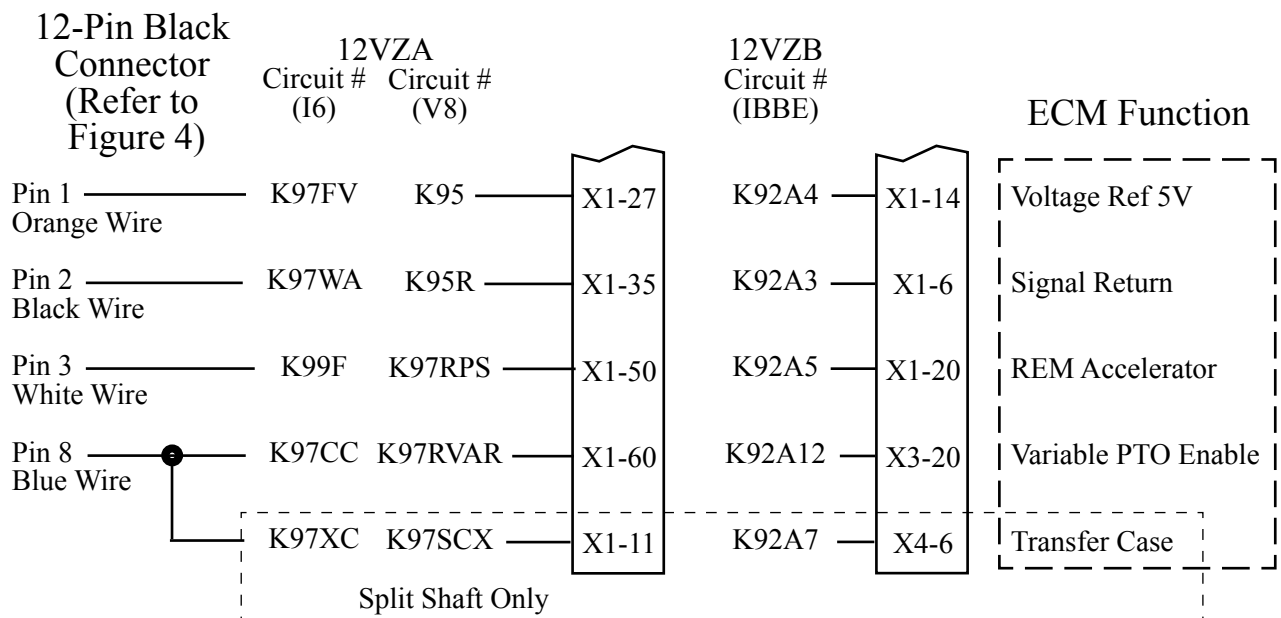

Figure 9. Navistar PBA504 Wiring

Caterpillar Harness Connections

Interface Information

The parameter settings for PTO Configuration is programmed to Remote Throttle with J1939 Speed Command.

Refer to an authorized dealer to program one of these options.

C7, C9, C10, C11, C12, C13, C15 Engine Interface

Engines with 70-pin OEM connector.

Note: Refer to Figure 4. PBA Connector Wiring for power and interlock wire connections.

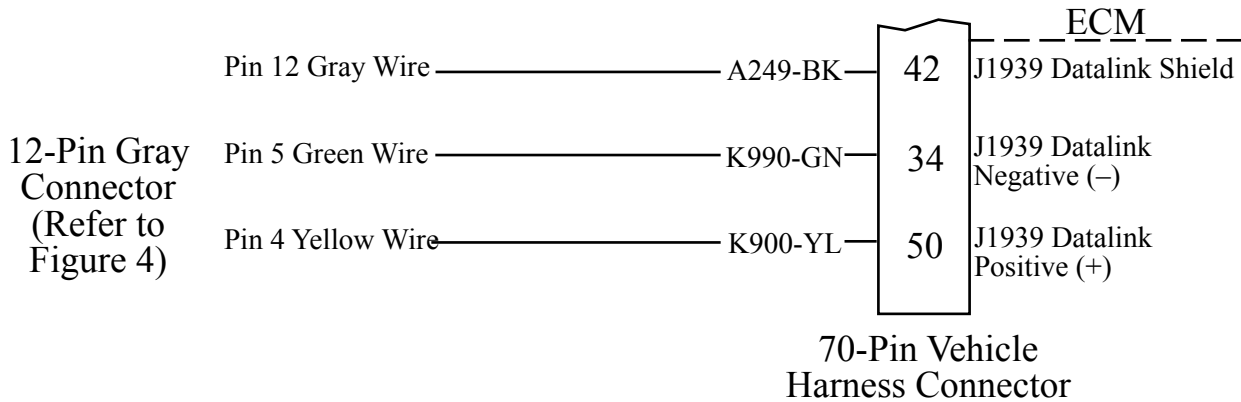

Figure 10. Caterpillar PBA505 Wiring

Ford Harness Connections

J1939 Interface Information

A J1939 CAN input is required to provide engine information to the governor. The Ford vehicle CAN Bus information needs to be interpreted. A J1939 Translator Module with a harness to connect it to the ODB-II connector must be installed.

Note: The ODB-II connector and wiring is accessed under the dash.

There are two scenarios:

- I. The J1939 Translator Module is installed as a component with governor kit (no Seat Belt Monitoring System is installed).

Install the J1939 Translator Module and the ODB-II interconnecting harness (provided with the governor kit). A 2-Pin connector is provided for the wires to governor.

- II. The J1939 Translator Module is installed as part of the NFPA1901 compliant Seat Belt Monitoring and VDR System.

The Translator Module/ODB-II/VDR harness is under the driver side dash. A T-cable (provided with the governor kit) needs to be installed at the 4-Pin connector that is between the harness and the VDR.

Stationary Elevated Idle Control (SEIC) Interface Information

Note: Access wires for SEIC are located in cabin, tagged and bundled above the parking brake pedal assembly behind datalink connector.

SEIC is used in two modes: stationary and split shaft. The governor provides a variable RPM control to the Ford Power train Control Module (PCM) when all enabling conditions are met. Refer to Figure 14 Ford PBA PCM Wiring.

SEIC Enablers: Parking brake applied; Foot off of service brake; Vehicle in park; Foot off of accelerator pedal; Vehicle speed is 0 mph (stationary); Engine at a stable base idle speed.

Note: Do not press the accelerator or service brake pedal when engaging the fire pump, this prevents the switch into SEIC.

Install the J1939 Translator Module with the ODB-II Interconnecting Harness or Install the T-cable between 4-Pin connectors.

To install the J1939 Translator Module with ODB-II harness, read and follow the installation instructions provided with the Translator Module kit.

Note: The TEST pad on the module circuit board has to be held at ground when the harness connector is plugged into the J1 connector.

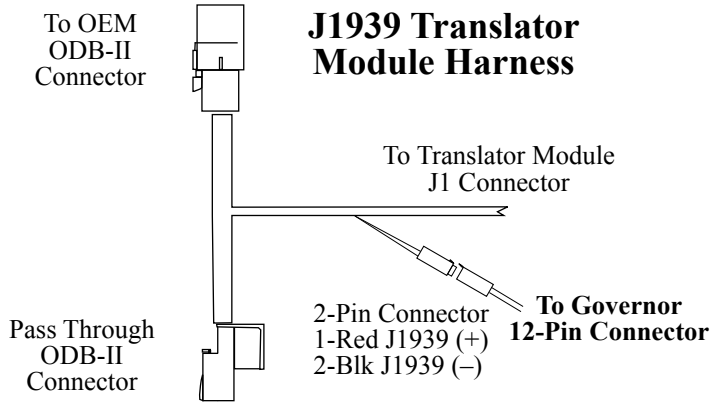

J1939 Translator Module

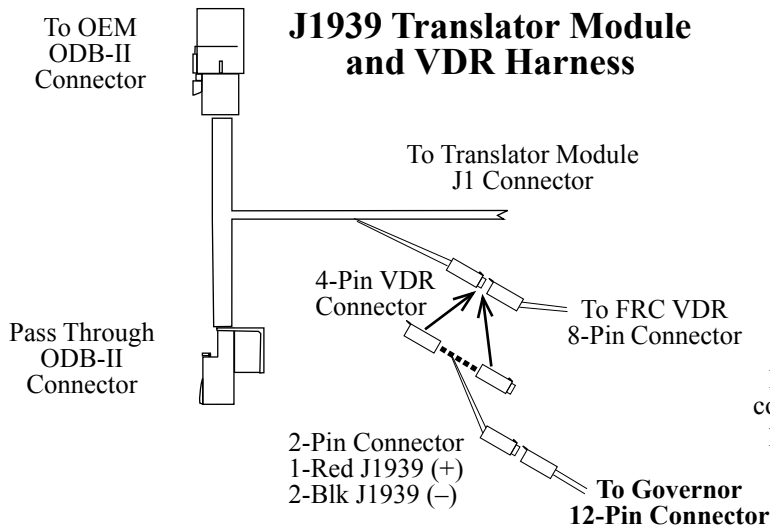
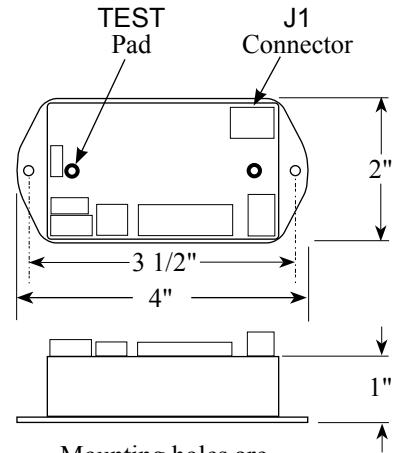

Disconnect VDR harness 4-Pin connector and connect the T-cable provided with the governor kit.

**Translator Module
Harness to Governor**

PBA506
12-Pin
Gray
Connector
(Refer to
Figure 4)

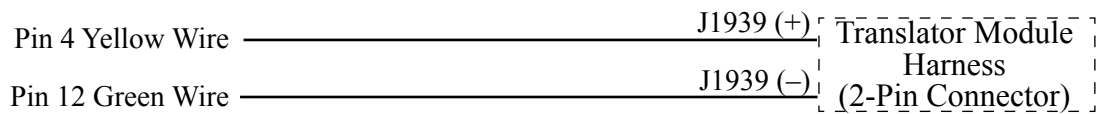

Note: Refer to Figure 4. PBA Connector Wiring for governor power and interlock wire connections.

Figure 11. Ford PBA506 J1939 Translator Module Wiring

2011 Model F-250/350/450/550 - 6.7L Diesel Engine Stationary Elevated Idle Control (SEIC)

Note: Do not press the accelerator or service brake pedal when engaging the fire pump, this prevents the switch into SEIC.

Note: Refer to Figure 4. PBA Connector Wiring for power and interlock wire connections.

Access wires for SEIC are located in cabin, tagged and bundled above the parking brake pedal assembly behind datalink connector.

Stationary Mode

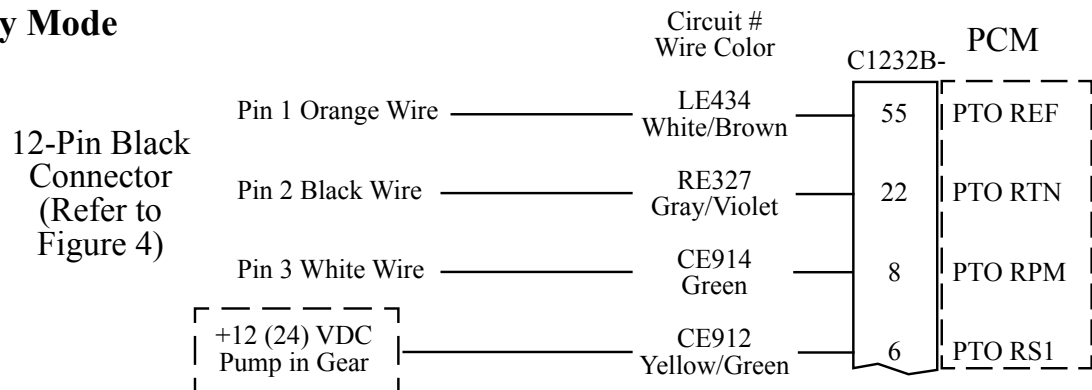

Split Shaft Mode

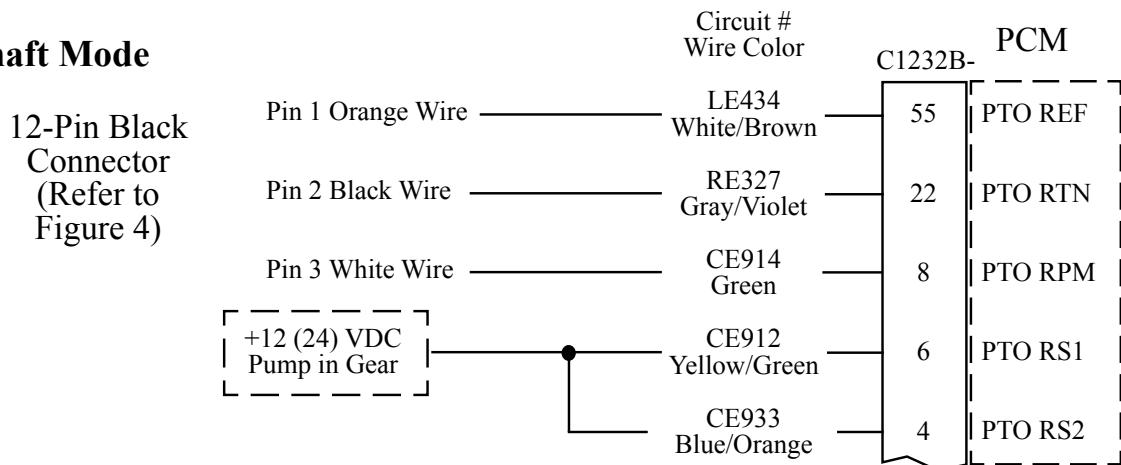

Split Shaft Mode is activated by applying supply voltage to both the PTORS1 and PTORS2 PCM circuits simultaneously.

1. Assure engine is running and fully warmed-up.
2. Apply parking brake.
3. Transmission in neutral to disengage drive wheels.
4. **With foot off brake and accelerator**, switch Split-Shaft PTO on.
5. **While pressing the service brake, shift transmission into drive.**
6. Engage PTO load.

NOTE: *Refer to Ford SVE Bulletin for SEIC details. (For 2017, see Q-256 Ford bulletin.)
(For 2016 and older, see Q-180R4 Ford SVE Bulletin.)

Once the system enablers are met voltage may be added to the SEIC system for activation. If power is applied prior to the enablers being met, a system error may occur, and the SEIC system will have to be reset.

If an SEIC disabler occurs the engine requires a change-of-state, meaning the operator is required to turn off voltage to the PTO-Request circuit, and back on again to re-invoke SEIC and PTO operation.

Figure 12. Ford PBA506 PCM Wiring

Mack Harness Connections

Interface Information.

For V-MACK IV 07 and newer, the governor is designed to control engine throttle directly over the SAE J1939 databus.

Note: Refer to Figure 4. PBA Connector Wiring for power and interlock wire connections.

J1939 CAN Bus Control

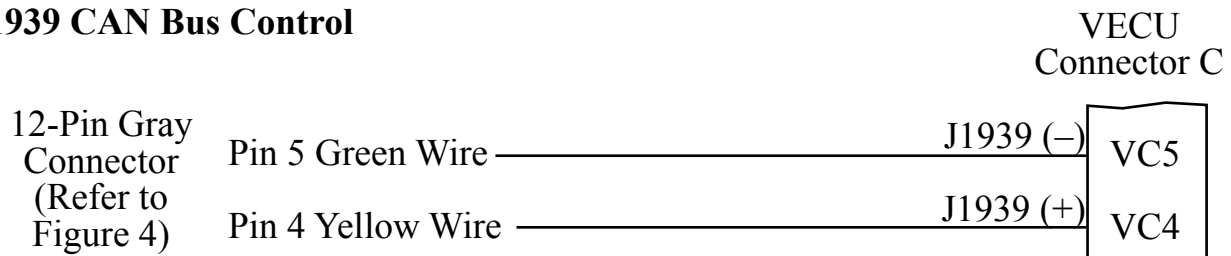
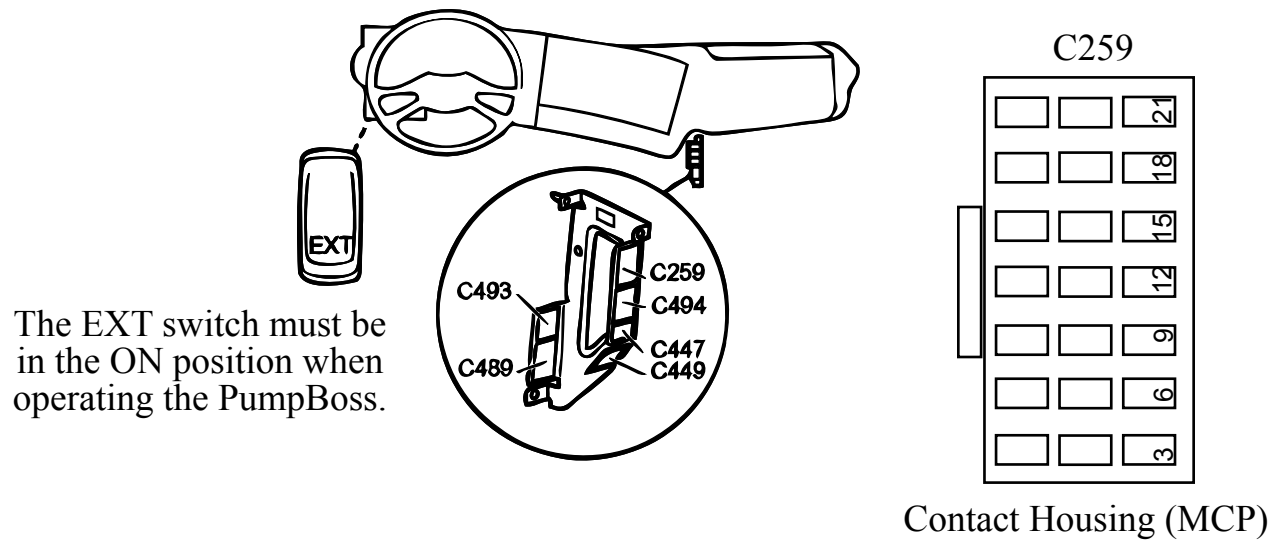

Figure 13. Mack PBA507 Wiring

Scania Harness Connections—Type A

Interface Information

For use on P, R, and T-series trucks equipped with a bodywork control unit (BWS). Connector C259 is available on all vehicles ordered with any of the bodywork options. It is located on the plate for the electrical bodywork interface for body builders. Connector C259 is white and has 21 pins. (February 2005 to 2015.)



Note: Refer to Figure 4. PBA Connector Wiring for power and interlock wire connections.

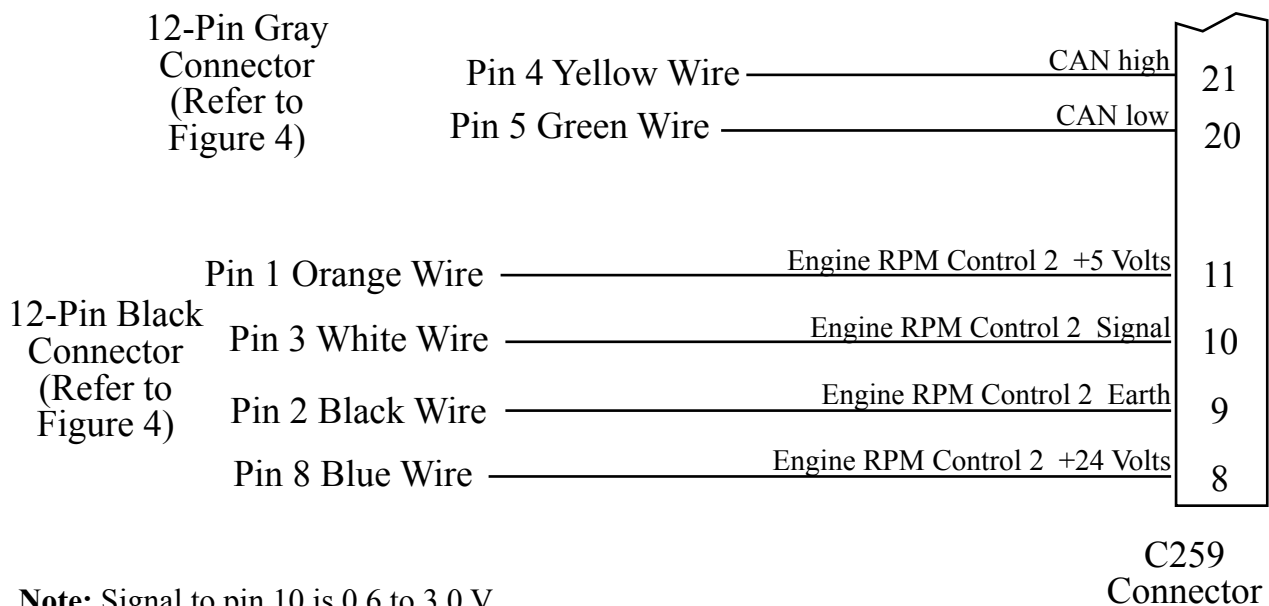

Note: Signal to pin 10 is 0.6 to 3.0 V

Figure 14. Scania PBA508 Wiring—Type A

Scania BCI Harness Connections—Type D

Interface Information

For use with BCI (Bodywork Communication Interface) module.

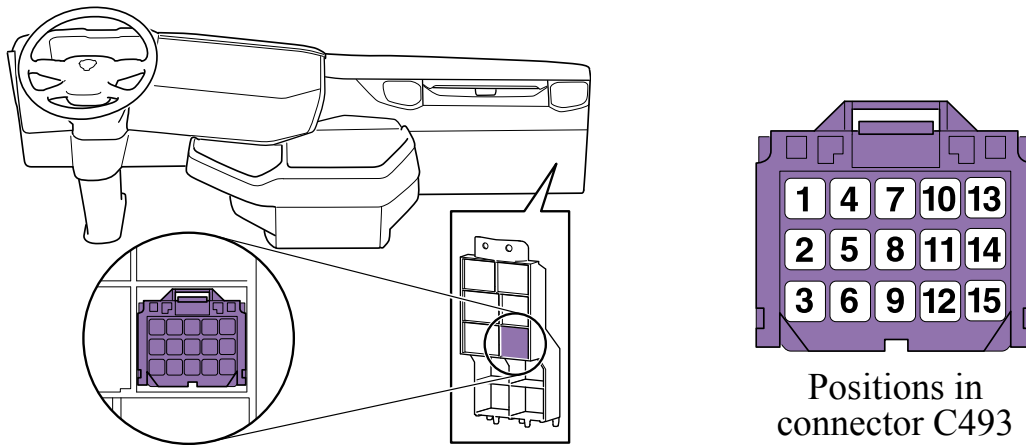

Connector C493 is located in the bodywork console.

Note: Refer to Figure 4. PBA Connector Wiring for power and interlock wire connections.

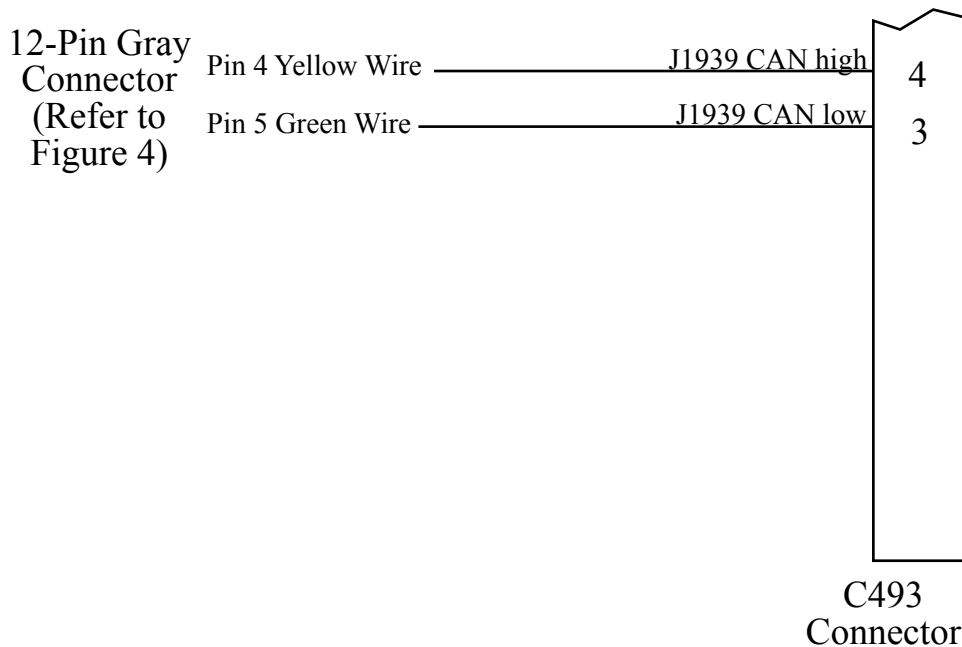

Figure 15. Scania BCI PBA508 Wiring—Type D

Mercedes Harness Connections

Interface Information.

For 2007 and newer engines, the governor is designed to control engine throttle directly over the SAE J1939 databus. Remote throttle does not need to be enabled in the ECM.

Note: Refer to Figure 4. PBA Connector Wiring for power and interlock wire connections.

For 2007 and Newer Engines

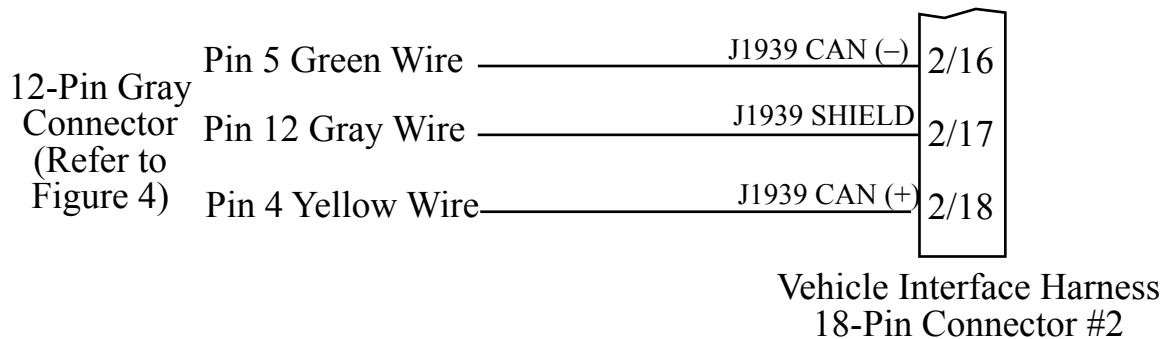

For 2006 and Older Engines

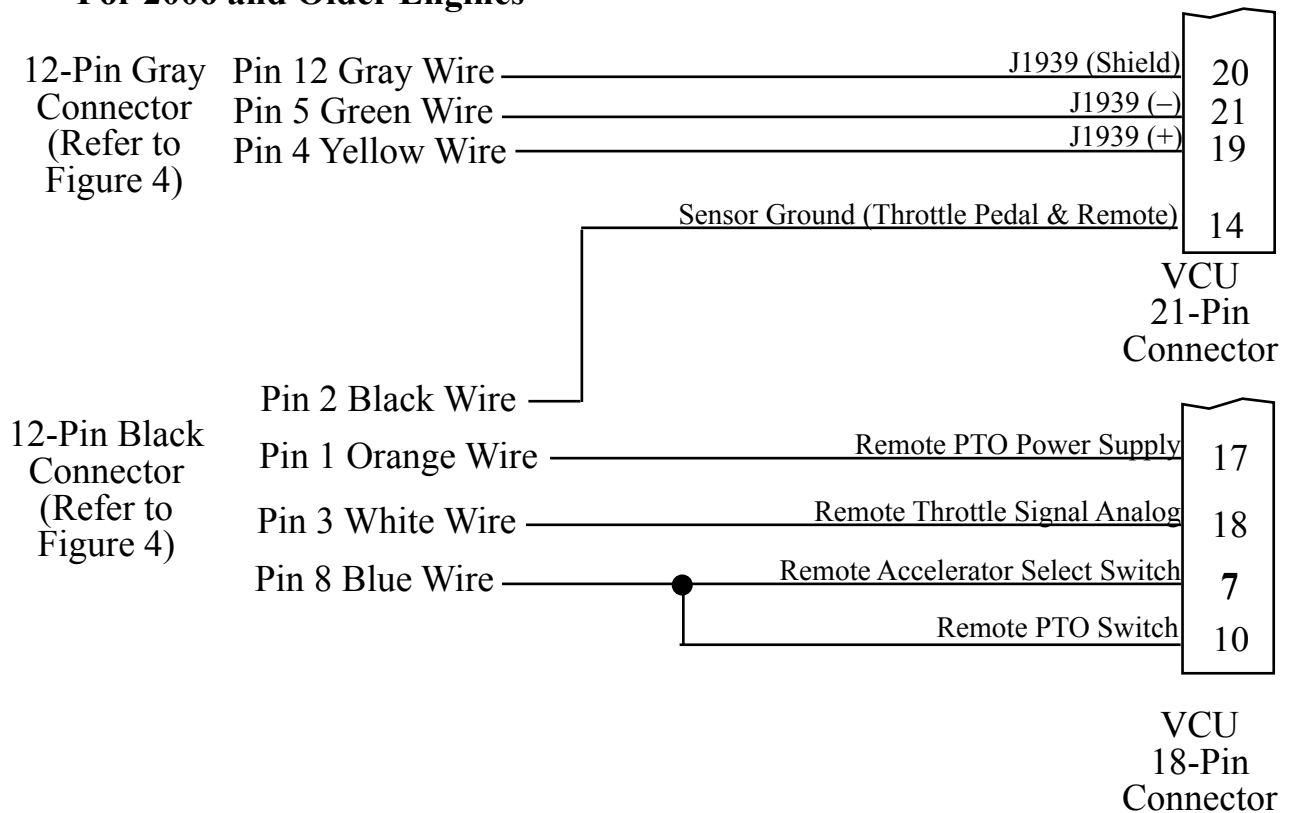

Figure 16. Mercedes PBA510 Wiring

John Deere Harness Connections

Interface Information

CAN Controller will request a torque by means of TSC1. This option is disabled by default and is selectable in the Trim Options page for this application. Source address 57 should be programmed.

Note: Refer to Figure 4 PMA500 Rear Connectors for Power and Interlock wire connections.

J1939 CAN Bus Control

TIER-3
PowerTech Engines

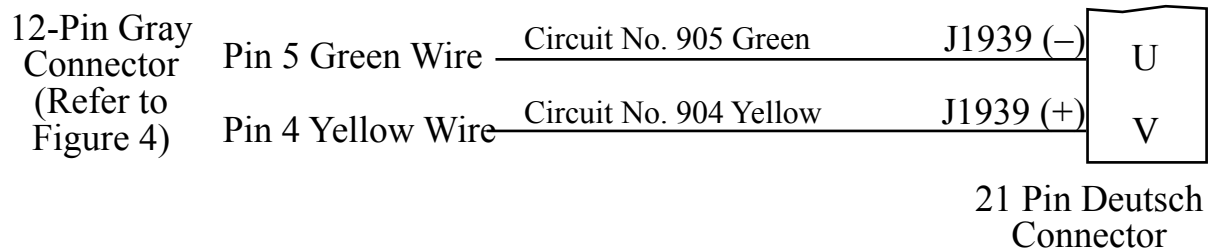

Figure 17. John Deere PBA516 Wiring

MAN Harness Connections

Interface Information

Parameters for various functions can be set on the KSM using MAN-cats II.

The KSM can accept the Engine speed request from the Governor on the A-CAN.

Note: Refer to Figure 4 PMA500 Rear Connectors for Power and Interlock wire connections.

J1939 CAN Bus Control

18-Pin Connector
X1997

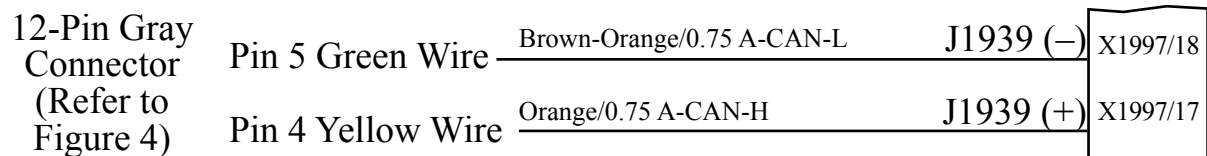

Figure 18. MAN PBA524 Wiring

IVECO Harness Connections

Interface Information

The vehicles shall be ordered with EM w/ CANopen (OPT0384) and FMS (OPT14569). The CANopen XDC needs to be downloaded. This service is available from the official IVECO TeleService tool-chain worldwide. Also an adapter cable needs to be installed to connect Controller to the CAN Bus. This option is currently available only for EURO CARGO-V.

Note: Refer to Figure 4 PMA500 Rear Connectors for Power and Interlock wire connections.

CAN Bus Control

Vehicle Interface Harness
9 Pin 72072C Connector

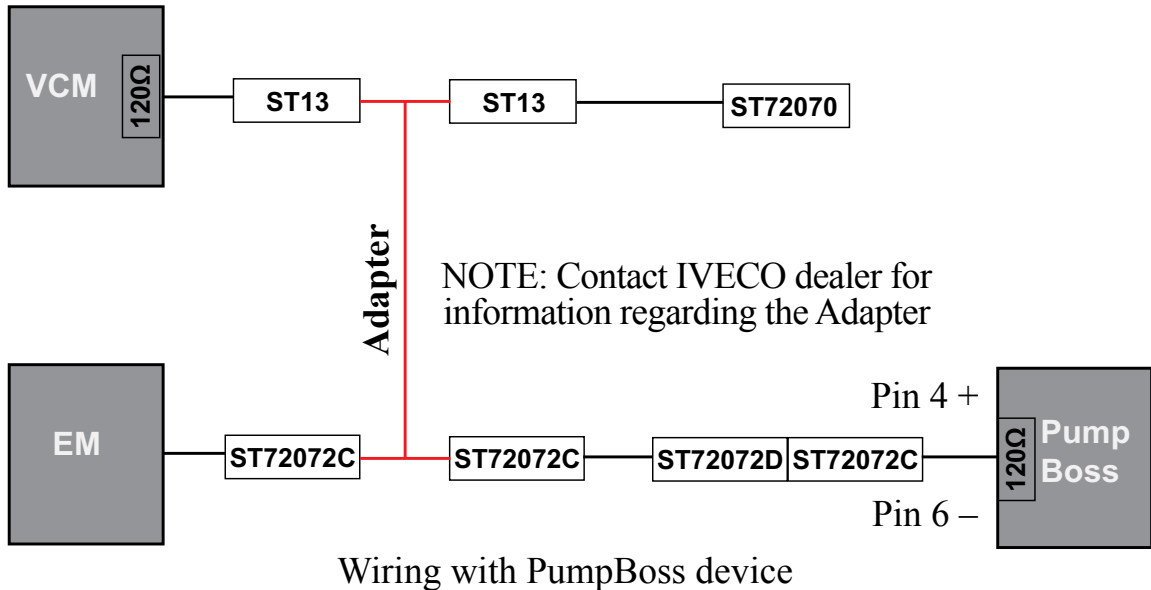
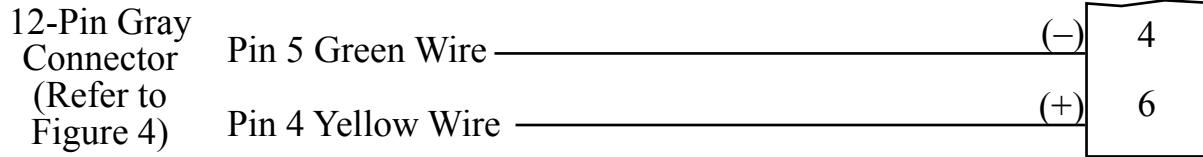

Figure 19. IVECO PBA526 Wiring

RAM Harness Connections

J1939 Interface Information

A J1939 CAN input is required to provide engine information to the governor. The RAM vehicle CAN Bus information needs to be interpreted.

Note: Specify Sales Code **LBN/LBV** for 3500/4500/5500 chassis CAB 6.7 Diesel Auto Transmission with PTO. (Sales Code **LBN** for Manual Transmission with PTO.)

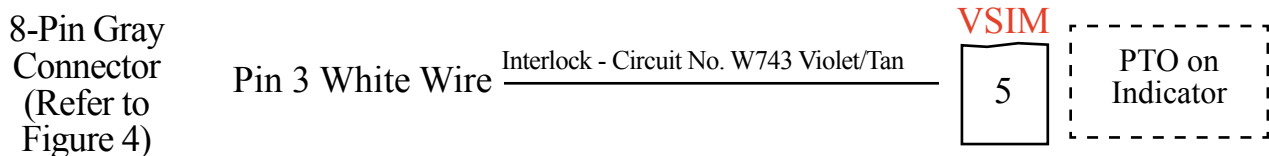
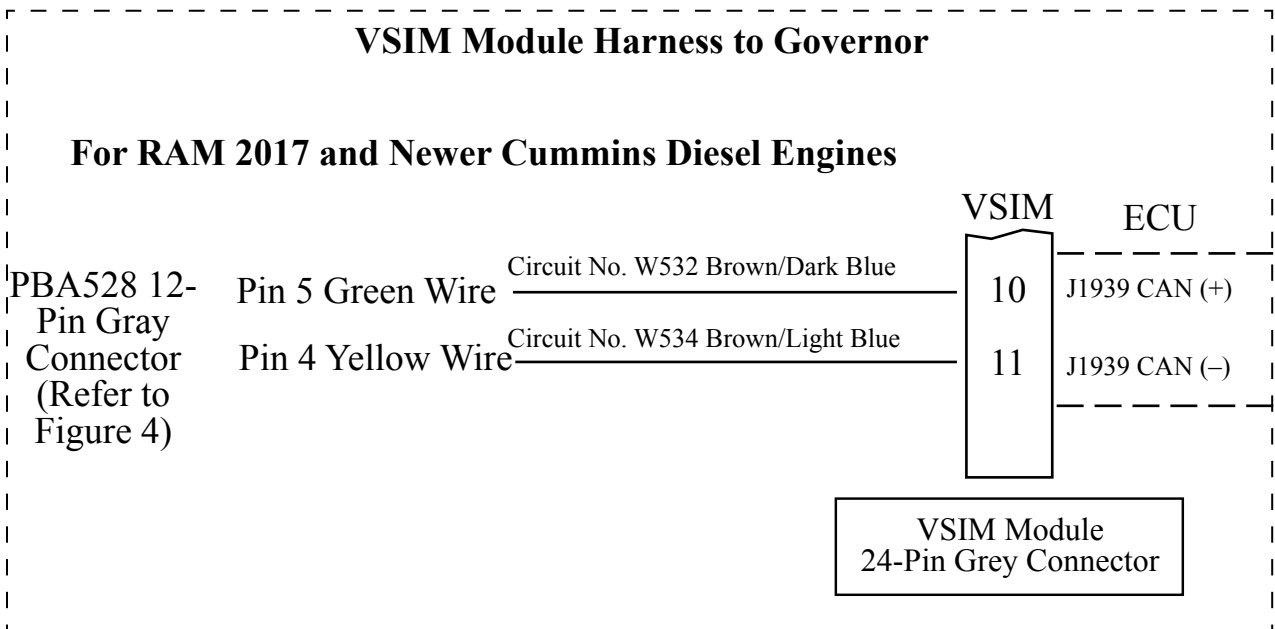

Note: Refer to Figure 4 PMA500 Rear Connectors for Power and Interlock wire connections.

Note: Verify the proper pump shaft turn ratio of the PTO shaft for proper pressure range. To keep the torque converter engaged, the RPM of the engine will ramp up to 1200 RPM, whether in Pressure or RPM modes of operation.

NOTE: *Refer to the *Dodge RAM Body Builder's Guide online for PTO operation details for 2017 and newer engines*. The following link will direct the user to the 'Updates' tab:

<https://www.ramtrucks.com/ram-commercial/body-builders-guide/vehicle-updates>.

For complete details, refer to both of the following documents in the most recent links:

Chassis Cab PTO Operation & Installation Guide

Chassis Cab VSIM Usage Instructions

Figure 20. Dodge Ram PBA528 VSIM Translator Module Wiring

2017 Model 3500/4500/5500 RAM Chassis Cab - 6.7 Cummins Diesel Engine

Note: Refer to Figure 5. PBA Connector Wiring for power and interlock wire connections.

Access connector for Remote Throttle is located at the Transmission Bellhousing Driver's side.

Stationary Mode

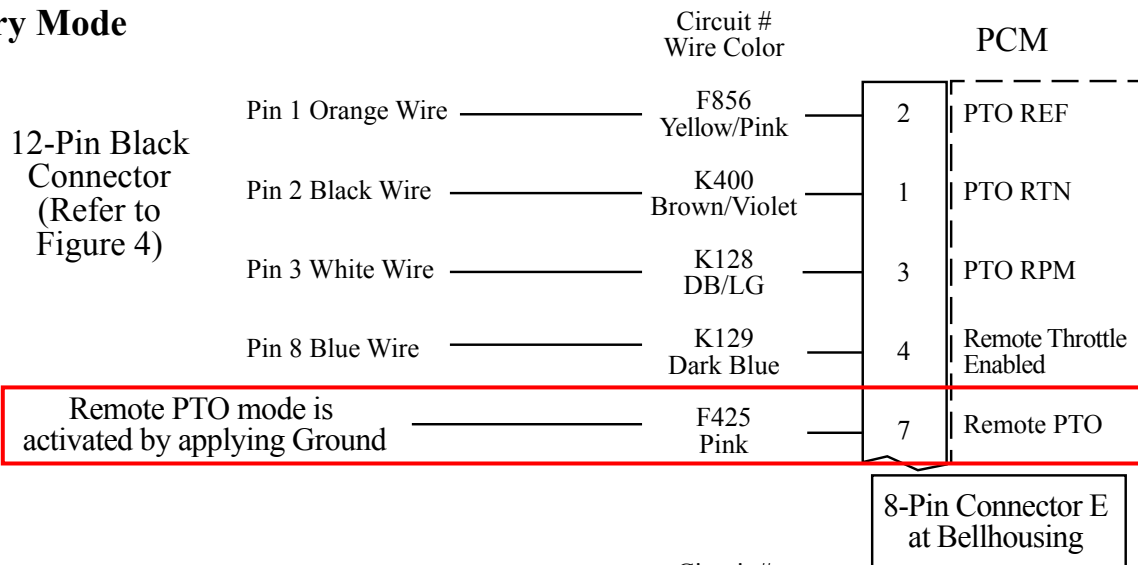

Split Shaft Mode

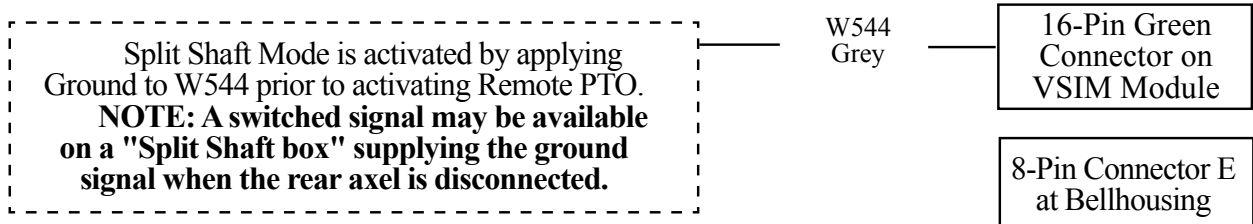
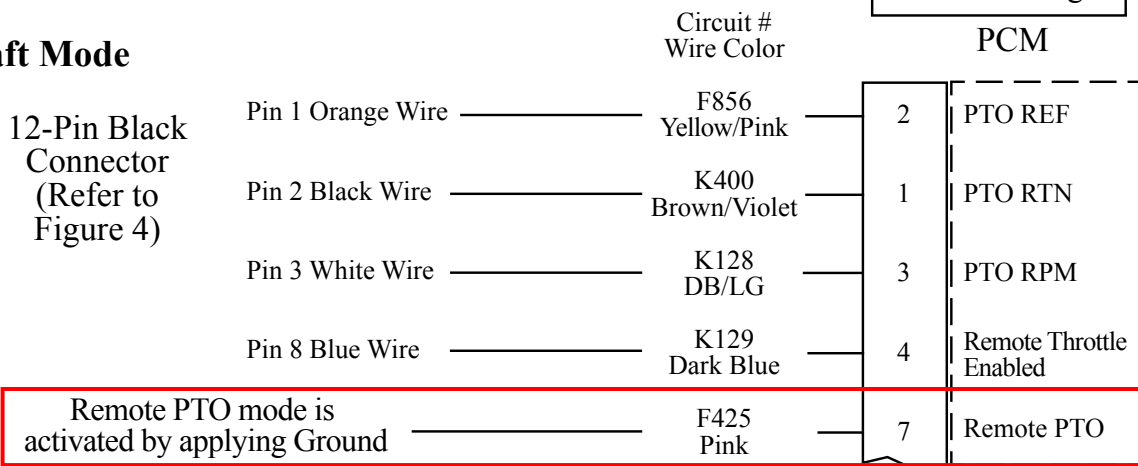

Once the system enablers are met voltage may be added to the Remote Throttle for activation. If power is applied prior to the enablers being met, a system error may occur, and the Remote Throttle operation will need to be reset.

If an Remote Throttle disabler occurs the engine requires a change-of-state, meaning the operator is required to turn off voltage to the PTO-Request circuit, and back on again to re-invoke Remote Throttle and PTO operation.

Figure 21. Dodge PBA528 PCM Wiring

High Idle Wiring

The governor programming includes a high idle function. To activate the high idle provide +12 VDC to 12 Pin Black connector pin#4 (High Idle Active Input) and +12 VDC to 12 Pin Gray connector pin#3 (Interlock I-Pump). The high idle connection to 12 Pin Black connector pin#4 must be isolated from the interlock circuit using two diodes (see schematic).

Note: It is important that the connection to the Interlock Input from the High Idle circuit be isolated from the apparatus interlock wiring with the two diodes. Refer to the wiring diagram. **The pump must NOT be engaged when using the high idle function.**

The high idle is set to 1000 RPM at the factory. (This value will vary depending on the specific engine.) To adjust this setting refer to High Idle in the Operation Section.

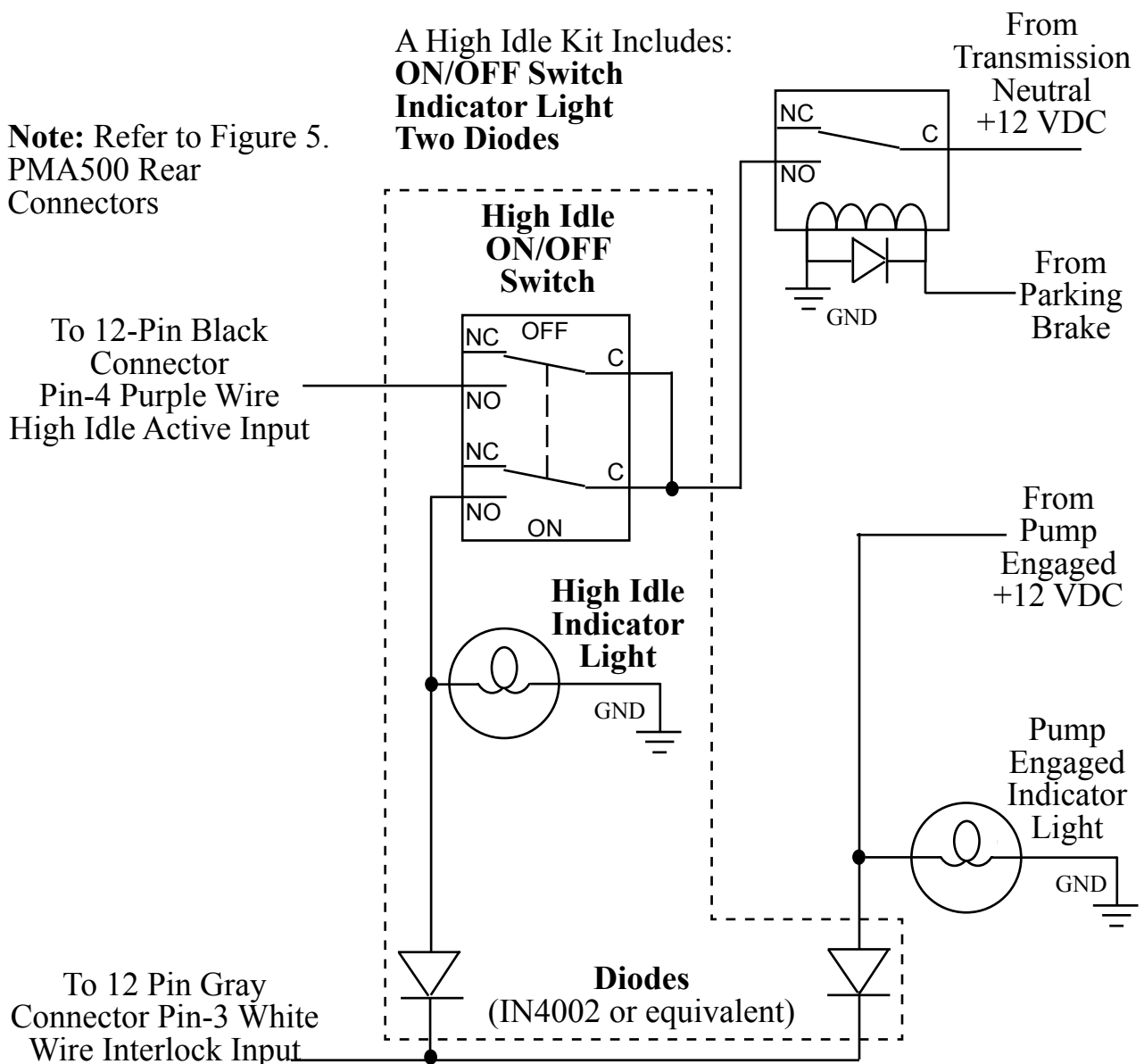

Figure 22. High Idle Wiring



DANGER

PERSONAL RESPONSIBILITY CODE

The member companies of FEMSA that provide emergency response equipment and services want responders to know and understand the following:

1. Firefighting and Emergency Response are inherently dangerous activities requiring proper training in their hazards and the use of extreme caution at all times.
2. It is your responsibility to read and understand any user's instructions, including purpose and limitations, provided with any piece of equipment you may be called upon to use.
3. It is your responsibility to know that you have been properly trained in Firefighting and/or Emergency Response and in the use, precautions, and care of any equipment you may be called upon to use.
4. It is your responsibility to be in proper physical condition and to maintain the personal skill level required to operate any equipment you may be called upon to use.
5. It is your responsibility to know that your equipment is in operable condition and has been maintained in accordance with the manufacturer's instructions.
6. Failure to follow these guidelines may result in death, burns or other severe injury.



Fire and Emergency Manufacturers and Services Association, Inc.
P.O. Box 147, Lynnfield, MA 01940 www.FEMSA.org

Copyright 2006 FEMSA. All Rights Reserved