



A Safe Fleet Brand

TANKVISION PRO

TANK INDICATOR

WLA300/400 WATER TANKS

WLA360/460 CLASS A FOAM CONCENTRATE TANKS

WLA370/470 CLASS B FOAM CONCENTRATE TANKS

PRIMARY and REMOTE DISPLAYS

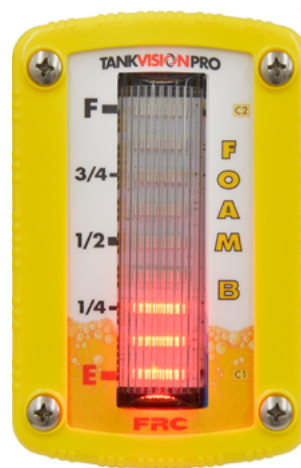
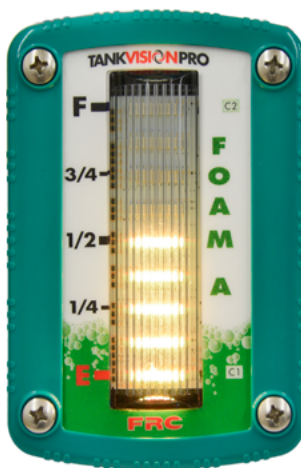
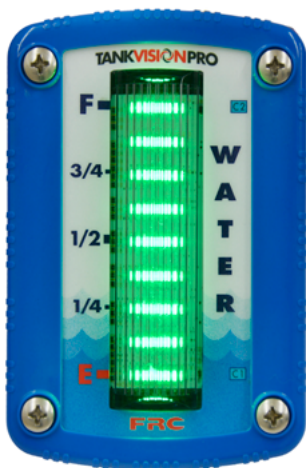

CAB
MINIATURES

MAXVISION
LED TANK
DISPLAY



FIRE RESEARCH CORPORATION

www.fireresearch.com

26 Southern Blvd., Nesconset, NY 11767

TEL 631.724.8888 FAX 631.360.9727 TOLL FREE 1.800.645.0074

CONTENTS

Table of Contents

CONTENTS.....	2
List of Figures.....	3
INTRODUCTION.....	4
Overview.....	4
Features.....	4
Specifications.....	6
GENERAL DESCRIPTION.....	7
Components.....	7
INSTALLATION.....	9
Install Display Module.....	9
Install Cab Miniature Display.....	9
Install Pressure Sensor.....	11
Install Pressure/Vacuum Foam Tank Vent.....	13
Install MaxVision LED Tank Display.....	15
Program MaxVision LED Tank Display.....	15
Install Remote Light Driver.....	19
Install Buzzer.....	19
OPERATION.....	20
Options.....	20
CALIBRATION.....	22
Overview.....	22
PROGRAMMING CODES.....	23
Calibration and Tank Level Correction.....	23
Non-Linear Calibration.....	24
Linear Calibration.....	25
DIAGNOSTICS.....	26
COLOR PATTERN SELECTION.....	28
Warning and Control Level Adjustment.....	29
Brightness Adjustment.....	31
Primary and Remote Synchronization.....	31
WIRING.....	32
Primary Display (WLA3XX/WLA4XX).....	32
WIRING.....	33
Primary Display Rear View (WLA3XX/WLA4XX).....	33
Remote Displays (WLA3XX/WLA4XX).....	34
Cab Miniature and MaxVision LED Displays.....	35
Remote Light Driver.....	36

Typical System Configuration WLA3XX.....	37
Typical System Configuration WLA4XX.....	38
CLEAN/INSPECT PRESSURE/VACUUM FOAM TANK VENT	39
PARTS LIST	40

List of Figures

Figure 1. Display Module Mounting Dimensions	10
Figure 2. Cab Miniature Display Mounting Dimensions.....	10
Figure 3. Pressure Sensor.....	12
Figure 4. Pressure/Vacuum Foam Tank Vent	14
Figure 5. MaxVision Color Pattern Programming.....	17
Figure 6. MaxVision LED Display Mounting Dimensions	18
Figure 7. Remote Light Driver.....	19
Figure 8. Diagnostics - Faults	26
Figure 9. Diagnostics - Warnings.....	27
Figure 10. Color Pattern Selection.....	28
Figure 11. Diagnostics - Warnings.....	29
Figure 12. Primary Display Wiring	32
Figure 13. Primary Display Wiring (Rear View)	33
Figure 14. Remote Display Wiring (WLA3XX/WLA4XX).....	34
Figure 15. Cab Miniature and LED Display Wiring	35
Figure 16. Remote Light Driver Wiring	36
Figure 17. Typical System Configuration WLA3XXX.....	37
Figure 18. Typical System Configuration WLA4XXX.....	38
Figure 19. Clean and Inspect Pressure/Vacuum Foam Tank Vent	39
Figure 20. WLA300 Parts List.....	40
Figure 21. WLA400 Parts List.....	41

INTRODUCTION

Overview

The FRC TankVisionPro indicator shows the actual volume of liquid in a tank. The liquid in the tank exerts a pressure that is measured by a sensor. As the amount of liquid changes, the pressure it exerts on the sensor changes proportionally. The pressure change is used to calculate the exact volume of liquid in the tank. The TankVisionPro can be calibrated to accurately display the volume of liquid in tanks of all shapes and sizes.

The display module is able to communicate with other display modules over the FRC datalink. This allows for one master display module to control multiple displays. The module also provides an output for cab miniature displays, remote light drivers, and a low level warning buzzer.

The TankVisionPro indicator is a unique design made up of an extended wide view lens with 9 or 10 super bright LEDs (depending on the chosen configuration) mounted behind it. This allows the display to be visible and clearly read from all line-of-sight angles for a full 180 degrees.

The pressure/vacuum foam tank vent is supplied for use on foam concentrate storage tanks. These tanks should remain closed to the atmosphere. The FRC vent enables the tank to compensate for changes in pressure or vacuum due to thermal expansion, filling, or when withdrawing foam concentrate from the tank.

The MaxVision LED tank display provides a remote, wide angle view of how much water or foam concentrate is left in the tank in fractional 1/8 tank eight level increments.

The remote light driver provides the option to have four 60 watt remote lights controlled by the TankVisionPro to show full, 3/4, 1/2, and 1/4 tank.

Features

Self-Calibrating for Any Shape or Size Tank

Visual Warnings At 1/4 and Almost Empty Tank Conditions

Multiple Remote Displays

Pressure/Vacuum Foam Tank Vent for Sealed Foam Tanks

Color Coded for Water, Class A, or Class B Foam

Self-Diagnostic Capabilities

Cab Miniature Display (Optional)

MaxVision LED Tank Display (Optional)

Remote Light Driver (Optional)

Low Level Warning Buzzer (Optional)

Tank Thin Wall Adapter Kit (Optional)

Output for Foam Fill and Auto Tank Systems (Factory Programmed)

Adjustable/Programmable Brightness Levels—10 adjustable brightness control levels

Tri-Color LEDs (Red, Green and Blue)—Programmable in various light patterns.
(See pages 27-28 for more detailed information.)

Magnet activated switch for calibration and settings

Option for 12 pin connector with additional features:

- Visual warning output

- Silence button input to disable audio warning only

- Valve control output

Frame attachment is provided for a more secure mounting

Waterproof Polycarbonate Housing and lens enclosure provided to protect electronics.

Specifications

Display Module

Supply Voltage:	9 - 30 VDC
Supply Current:	0.25 Amp Maximum
Dimensions:	4 3/8 by 3 Inches
Housing:	Waterproof Polycarbonate with plastic lens and enclosure to protect electronics
Indicators:	Tri-Color of Bright LEDs (9/10 Rows)
Viewing Angle:	180°

Cab Miniature Display

Supply Voltage:	9 - 30 VDC
Supply Current:	0.5 Amp Maximum
Dimensions:	2 1/4 by 1 1/2 Inches

MaxVision LED Tank Display

Supply Voltage:	12/24 VDC
Supply Current:	1 Amp Maximum at 12 VDC
Dimensions:	14 3/8 by 1 7/8 Inches
Indicators:	96 Super Bright LEDs

Remote Light Driver

Supply Voltage:	9 - 30 VDC
Supply Current:	0.1 Amp Maximum
Switch:	Solid State
Switching Voltage:	9 - 30 VDC
Switching Current:	20 AMPS Maximum @ 12 VDC 10 AMPS Maximum @ 24 VDC

Pressure Sensor

Housing:	Stainless Steel with 1/4-18 NPT for Mounting
Sensor:	Ceramic Diaphragm
Pressure Range:	0 - 5 PSI (Maximum Tank Height - 10 Feet)
Excitation Voltage:	5 VDC

Pressure/Vacuum Foam Tank Vent

Material:	PVC and Aluminum with Delrin Valves
Relief Pressure:	±0.01 PSI
Maximum Flow Rate:	Compensates 100% for Concentrate Flow Rates Below 60 GPM

GENERAL DESCRIPTION

Components

The TankVisionPro consists of the following components:

Display Module

Cab Miniature Display (Optional)

Pressure Sensor

Pressure/Vacuum Relief Vent (Foam Tanks)

MaxVision LED Tank Display (Optional)

Remote Light Driver (Optional)

Buzzer (Optional)

Cables

Display Module

The tank display module is waterproof and has dimensions of 4.4 inches high by 3 inches wide. An output signal from a pressure sensor mounted on the tank is input to the primary display module. It is processed and the volume of liquid in the tank is shown on the 9 LED display as a fractional amount on the overlay (or available as a percentage value for a 10 LED display). Outputs from the primary display module provide tank volume information to other displays and remote devices.

WLA400 Series primary displays are used for Auto Tank ATA400 systems. WLA300 Series primary displays can be programmed to use pin #5 for Auto Tank ATA400 systems.

Cab Miniature Display (Optional)

The cab miniature display has dimensions of 2.75 inches high by 1.5 inches wide. It provides the option of mounting a remote display in the cab that uses a minimum of panel space. An output signal from the primary display module is input to the cab miniature display and the volume of liquid in the tank is shown on the 5-LED display.

Pressure Sensor

The pressure sensor is mounted on a side of the tank near the bottom. It provides a signal that is proportional to the volume of liquid in the tank to the input of the primary display module. The electrical connector is waterproof and molded into the pressure sensor housing.

The standard pressure sensor is used on tanks between 1 and 10 feet in vertical height. For tanks taller than 10 feet contact FRC for options.

Pressure/Vacuum Foam Tank Vent

The pressure/vacuum foam tank vent is supplied for use on sealed foam tanks. The vent compensates for changes in tank pressure due to thermal expansion or when withdrawing foam concentrate from the tank. Internal passageways provide a path for air to move between the tank and a center cavity in the vent. These passageways are self-draining and designed to prevent splashing foam from entering the center cavity and clogging the pressure and vacuum valves. The pressure and vacuum valves are easily accessed and disassembled for periodic cleaning or inspections. (Refer to Maintenance section.)

Note: The vent can compensate for a maximum foam concentrate flow rate of 60 GPM. If the flow rate of foam concentrate from the tank will exceed 60 GPM, two (2) vents will be required.

MaxVision LED Tank Display (Optional)

The LED display is waterproof and has dimensions of 14 3/8 inches high by 1 7/8 inches wide by 7/8 inch deep. It has 96 RGB LEDs and built in LED drivers. A signal from the primary display module is output on a two wire datalink and input to the LED light to show the volume of liquid in the tank.

The display shows the level in 1/8 tank increments. It has a photo sensor that adjusts brightness for day or night operations. The LEDs are programmable for various display modes and multiple brightness levels:

Note: The MaxVision LED tank display shows how much water or foam concentrate is left in the tank in fractional 1/8 tank eight level increments.

Remote Light Driver (Optional)

The remote light driver is waterproof and has dimensions of 4 inches high by 2.75 inches wide by 1 inch deep. An output signal from the primary display module is input to the remote light driver. This provides the option to power four (4) 60 watt remote lights that show the volume of liquid in the tank. The lights will show full, 3/4, 1/2, and 1/4 tank levels.

Buzzer (Optional)

The buzzer provides an audio alarm when the tank volume drops to 25%. The buzzer resets when the tank volume goes above 25%.

Note: When the TankVisionPro WLA300 primary display is used to control an Auto Tank ATA400 system, pin 5 does not provide a ground for the buzzer. WLA400 Series primary displays are used for Auto Tank ATA400 systems. WLA300 Series primary displays can be programmed to use pin #5 for Auto Tank ATA400 systems.

INSTALLATION

The TankVisionPro primary display module is connected to the pressure sensor and is the only module that needs to be calibrated.

Note: The calibration procedure needs to be performed every time a primary display module is installed.

Install Display Module

The full size display modules all have the same mounting dimensions. Standard display modules are interchangeable.

Note 1: It is recommended to mount the display at eye level.

Note 2: Do not use Loctite on any screws near the Lexan lens. Lexan lenses can become brittle and prone to cracking when exposed to Loctite compounds.

1. Measure and mark mounting location for display module panel cutout and mounting screw holes. Make sure there is clearance behind the panel for the display and cables before cutting holes. Refer to Figure 1 for layout and dimensions.
2. Cut out a 4 by 2 1/8-inch hole and drill four (4) holes (clearance or tapped) for #10 mounting screws.
3. Place display module in position and secure with four (4) screws.
4. Connect the display module cables and wires. (Refer to Wiring Section.)

Install Cab Miniature Display

1. Measure and mark mounting location for cab miniature display mounting hole. Make sure there is clearance behind the panel before drilling hole. Refer to Figure 2 for layout and dimensions.
2. Drill a clearance hole for 3/8" threads.
3. Place cab miniature display in position and secure with nut.
4. Connect the cab miniature display wires. (Refer to Wiring Section.)

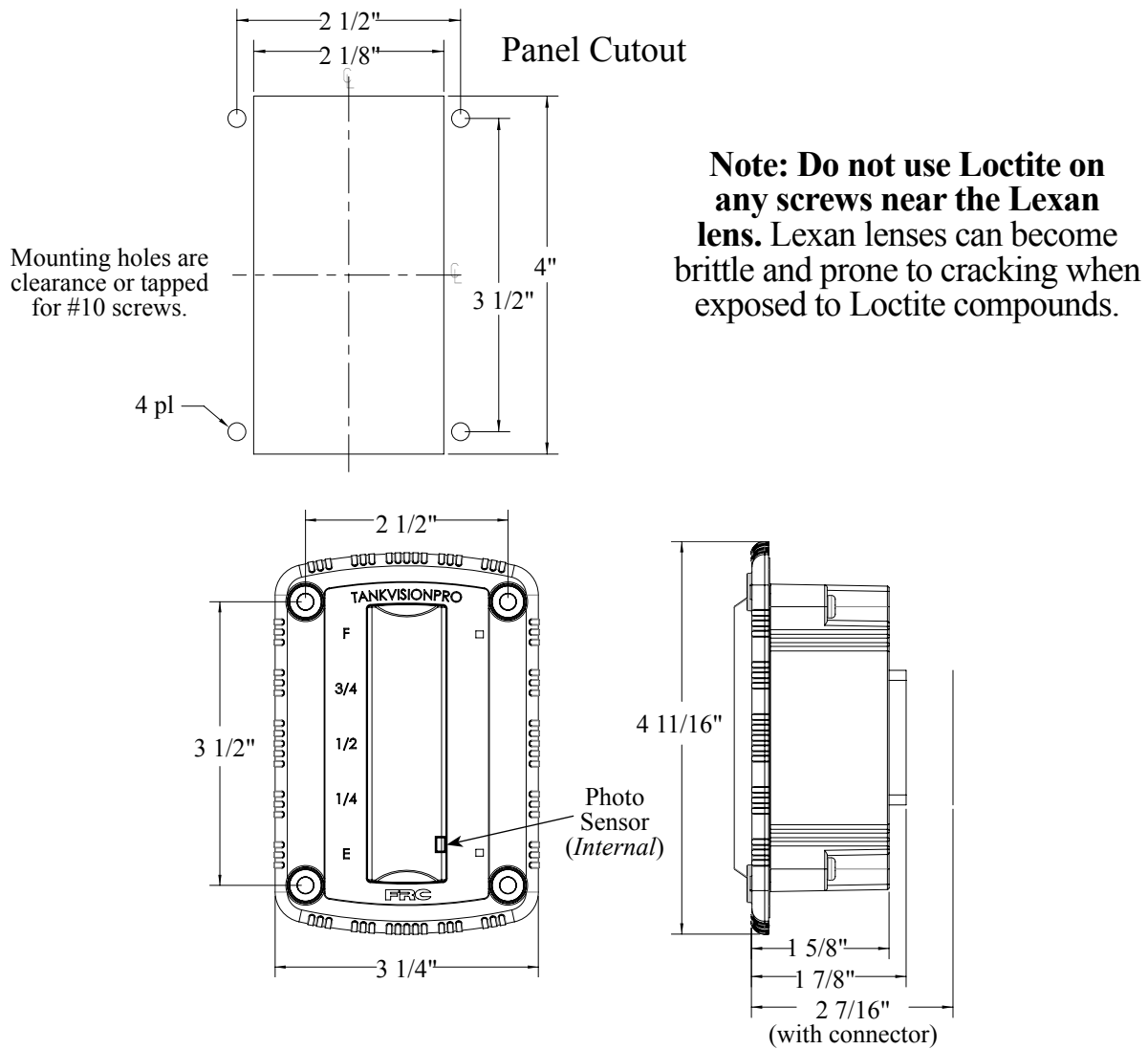

Figure 1. Display Module Mounting Dimensions

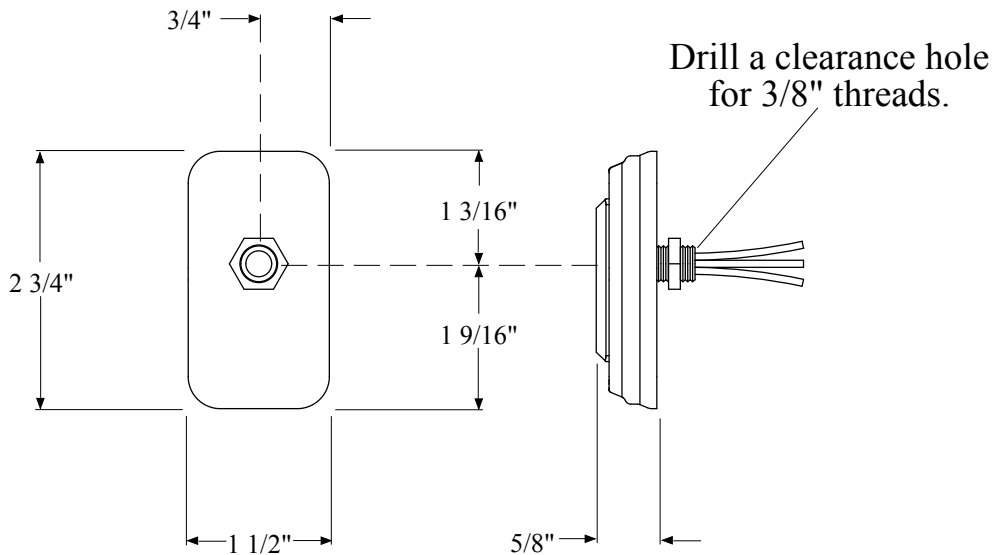

Figure 2. Cab Miniature Display Mounting Dimensions

Install Pressure Sensor

The pressure sensor is mounted on one of the tank sides approximately 2 inches from the bottom. If the tank has a vertical height greater than 10 feet contact FRC, a different sensor may be required.

Pressure sensors are interchangeable. It is recommended that the calibration procedure be performed if the pressure sensor is changed.

Note: When mounting the pressure sensor on a tank with thin walls, less than 3/8", it is recommended that the tank wall be reinforced at the sensor mounting location.

Pressure Sensor Installation

Note: *Do not mount the sensor in the bottom of the tank. Sediment may collect in the port and cause sensor failure.*

1. Measure and mark mounting location for sensor. (Mounting hole should be approximately 2" from bottom of tank.) Make sure there is clearance for sensor and cable before drilling hole. Refer to Figure 3 for dimensions.
2. Drill and tap a 1/4 NPT hole.
3. Apply sealant around base and threads of pressure sensor.
4. Screw sensor into hole.
5. Connect sensor cable. (Refer to Wiring Section.)

Thin Wall Adapter Installation

The thin wall adapter kit includes the adapter, two 10-24 x 5/8" screws, 5 minute epoxy, and a mixing stick.

1. Measure and mark mounting location for adapter. Make sure there is clearance for adapter, sensor, and cable before drilling hole. Refer to Figure 3 for dimensions.
2. Drill and tap a 1/2 NPS hole.
3. Screw the adapter into the hole.
4. Use the adapter as a template and drill and tap two 10-24 holes for two screws.
5. Back adapter out of hole and apply 5 minute epoxy to back of flange, on threads, and in two 10-32 through holes.
6. Screw adapter into hole and secure with two screws.
7. Allow the epoxy time to set.
8. Apply sealant around base and threads of pressure sensor and screw into adapter.
9. Connect sensor cable. (Refer to Wiring Section.)

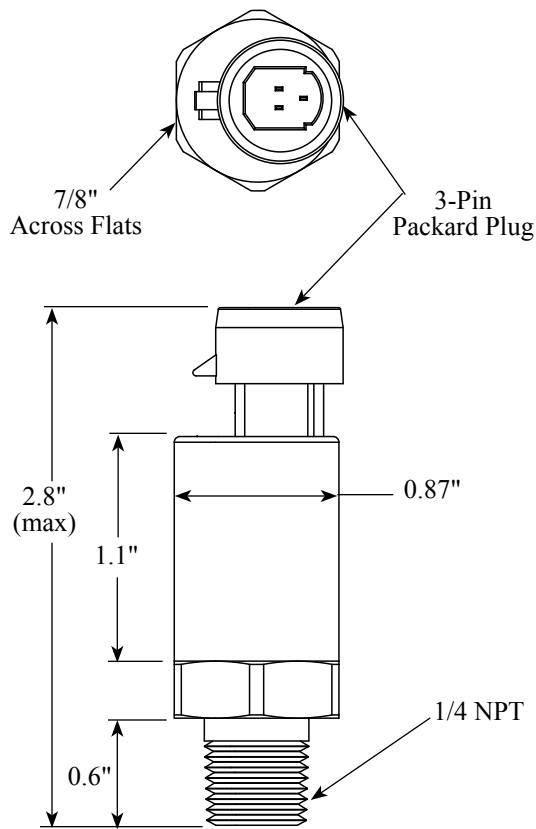

Apply sealant around base and threads.

Mount sensor approximately 2" from bottom of tank.

Typical Tank

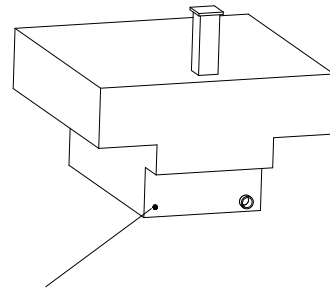

Typical Pressure Sensor Location

Note: Do not mount the sensor in the bottom of the tank. Sediment may collect in the port and cause sensor failure.

Note: The sensor can be mounted vertically on a 90° fitting in cold areas to help prevent water freezing in the sensor.

Thin Wall Adapter

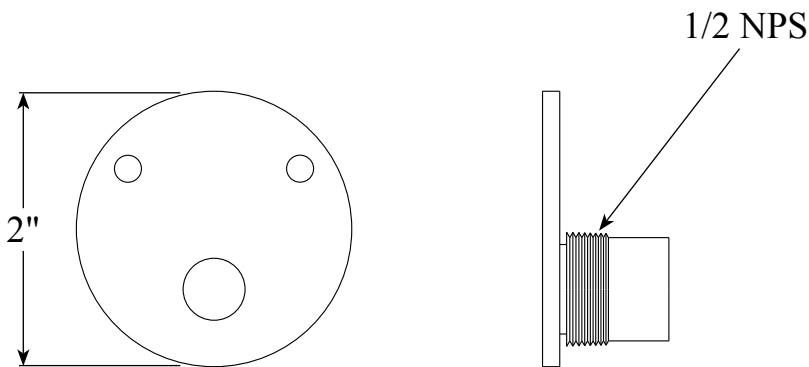

Apply sealant around base and threads of sensor.

Apply epoxy around flange, threads, and screws.

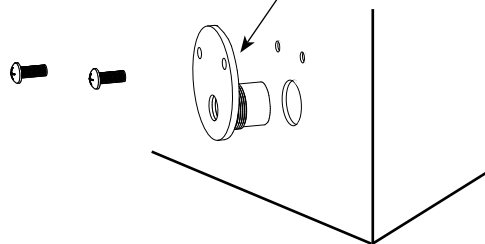

Figure 3. Pressure Sensor

Install Pressure/Vacuum Foam Tank Vent

A pressure/vacuum foam tank vent is supplied for use on sealed foam tanks. The recommended location to mount the vent is in the cover of the foam tank fill tower. If there is no fill tower, mount the vent at the highest point of the tank top so that it is not immersed in foam. For installations where clearance above the fill tower is limited, a 90° mounted vent is available.

Note: The vent can compensate for a maximum foam concentrate flow rate of 60 GPM. If the flow rate of foam concentrate from the tank will exceed 60 GPM, two (2) vents will be required.

Install Top Mounted Tank Vent

The top mounted tank vent is mounted in a vertical position through a 1 1/8-inch hole on the lid of the fill tower and is secured by a hand tightened nut.

Note: The tank vent must be in a vertical position and can not be immersed in foam.

1. Measure and mark mounting location for vent. Make sure there is clearance for the valve before drilling hole. Refer to Figure 4 for dimensions.
2. Drill 1 1/8-inch diameter hole.
3. Insert vent into the hole with the gasket in place.
4. Screw on nut and hand tighten.

Install 90° Mounted Tank Vent

The 90° mounted tank vent is mounted on a vertical side of the fill tower. It must be located as close to the top of the fill tower as possible. The vent is held in place with two (2) 1/4-20 x 3-inch bolts, washers, and locknuts.

Note: The tank vent must be in a vertical position and can not be immersed in foam.

1. Measure and mark mounting location for vent. Make sure there is clearance for the valve before drilling holes. Refer to Figure 4 for dimensions.
2. Drill 3/4-inch diameter hole and two through holes for 1/4-20 bolts.
3. Apply sealant to mounting surfaces and bolt holes.
4. Secure vent in place with two bolts, washers, and locknuts.

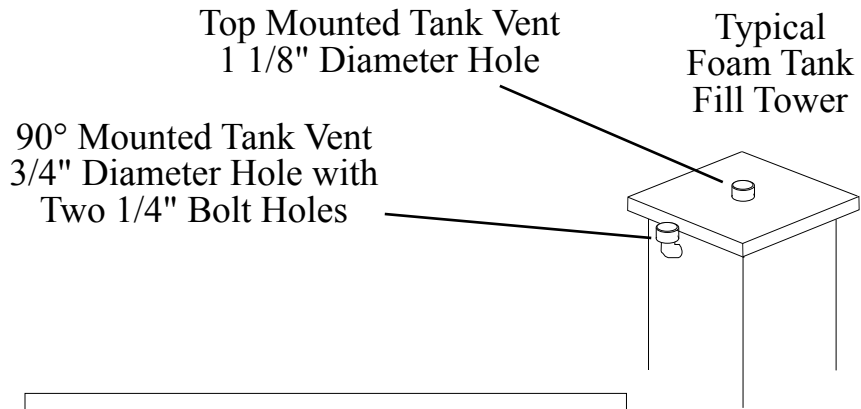

Note: The tank vent must be mounted in a vertical position. The vent can not be immersed in foam. (If there is no fill tower, mount the vent at the highest point of the tank top so that it is not immersed in foam.)

Top Mounted Tank Vent

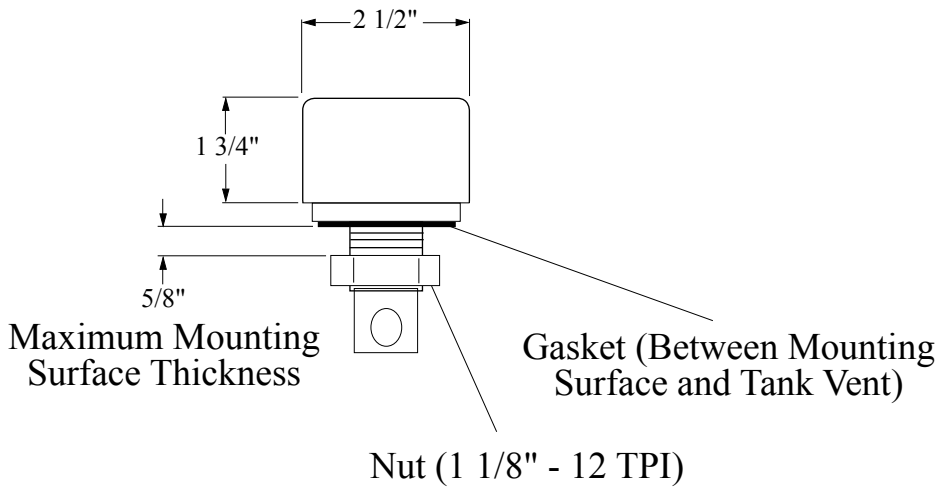

90° Mounted Tank Vent

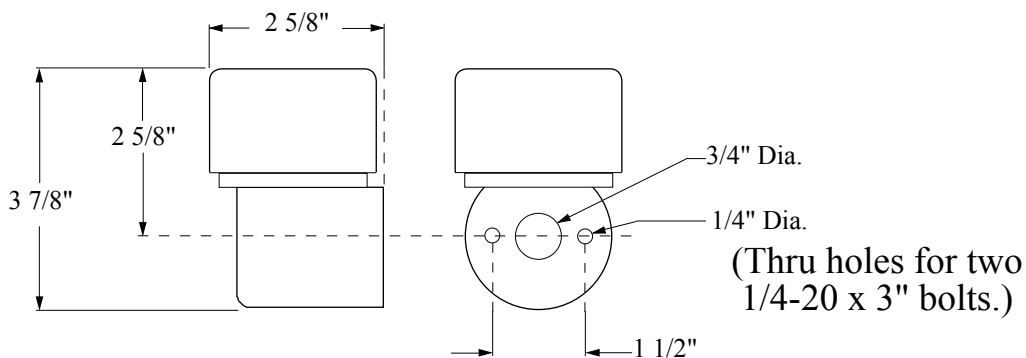

Figure 4. Pressure/Vacuum Foam Tank Vent

Install MaxVision LED Tank Display

The LED display is waterproof to allow for flexibility in the mounting location. Ensure that the light is mounted with the rear against a flat surface.

Mount the display so that the raised MaxVision logo on the lens and the drain notch on the rubber gasket are at the bottom and is mounted with the rear against a flat surface.

The wires can be run through any one of the three holes in the rubber gasket.

Note: Before drilling holes place the light in position to check for fit. Ensure that the display clears all obstructions.

1. Measure and mark the mounting hole locations and through hole for the wiring.
2. Drill the two (2) mounting holes for #10 screws and a wire feed thru hole. Any of the three locations (holes) in the rubber boot can be used for the wires.

Note: Ensure that the terminating resistor is installed on the datalink wires when required.

3. Connect the wiring and secure the light with two (2) screws. (Refer to Wiring Section.)

Terminating Resistor Notes

The datalink requires two terminating resistors.

1. One TankVisionPro with one or two LED displays: Install one resistor close to the primary display; install the other resistor farthest away from the primary display, but closer to the remote display.
2. Two TankVisionPro displays: Install terminating resistor at both ends.
3. If the TankVisionPro is used with a TurboFoam system: Do not install terminating resistor.

Program MaxVision LED Tank Display

The MaxVision acts as a remote, and the color pattern will mirror the pattern chosen for the primary display. (*See page 29 for detailed information about synching primary and remote displays.*)

Code Entry:

1. Hold a magnet over the calibration point for five seconds. Two middle rows of LEDs come on.
2. Swipe the magnet to select the program to be changed; a row of LEDs come on with each swipe.

Brightness Adjustment:

1. Top 2 rows on - set daytime brightness.
2. Top 3 rows on - set nighttime brightness.

3. Wait 5 seconds to enter the program.
4. Each swipe changes the LEDs brightness—ten levels that are stepped through and then repeated.
5. Hold the magnet over the calibration point for five seconds to load the new setting. The display blinks three times to confirm setting is loaded.

Programming the MaxVision to Display Foam A, Foam B or Water:

Code Entry:

- Hold a magnet over the calibration point for five seconds. Two middle rows of LEDs come on.

Swipe 4 times to set the display for one of the following options:

- Water (Default option)—displays alternate Blue LEDs
 - Foam A—displays alternate Green LEDs
 - Foam B—displays alternate Yellow LEDs
1. Wait 5 seconds to enter the program.
 2. Each swipe changes the choice from Water, to Foam A, to Foam B—the three options are stepped through and then repeated.
 3. Hold the magnet over the calibration point for five seconds to load and save the new setting. The display flashes or blinks three times to confirm setting is saved and updated.

Programming the Color Pattern for the MaxVision:

The default setting for the color pattern is to have this synchronized with the primary display (as described on page 29, Fig. 10). If it is required to have the MaxVision synchronize with the primary display, activate the "Code Entry" (as mentioned on page 15), *select Pattern #10, wait for 5 seconds and swipe the magnet once. Save the setting by holding the magnet for 5 seconds at the calibration point.*

However, these same six color patterns from Fig. 10 (shown in Fig. 5) can be "locked in" for the MaxVision only, separately from the color pattern shown on the primary display.

Additionally, there are three color patterns to display the status level of either Foam A (all Green LEDs), Foam B (all Yellow LEDs) or Water (all Blue LEDs). This allows for customizing of up to nine different "locked-in" color patterns on the MaxVision display (separate from the primary display).

Perform the following steps to select the locked in color pattern for the MaxVision:

1. Start the "Code Entry" by holding the magnet the calibration point for five seconds. Two middle rows of LEDs come on.
2. Swipe the magnet to select the program to be changed; a row of LEDs come on with each swipe.

3. Swipe the magnet once and in five seconds the previously saved color pattern will be displayed. The Red LEDs will all light up and scroll upward (as shown in Pattern 10). The Red LEDs scrolling upward means the MaxVision display is synchronized with the primary display. The color pattern on the MaxVision will be identical to the one on the primary display. (This is the default setting).

Each swipe changes the choice from each of the nine color patterns—the nine options are stepped through and then repeated.

4. Hold the magnet over the calibration point for five seconds to save the new color pattern setting. The display flashes or blinks three times to confirm setting is saved and updated.

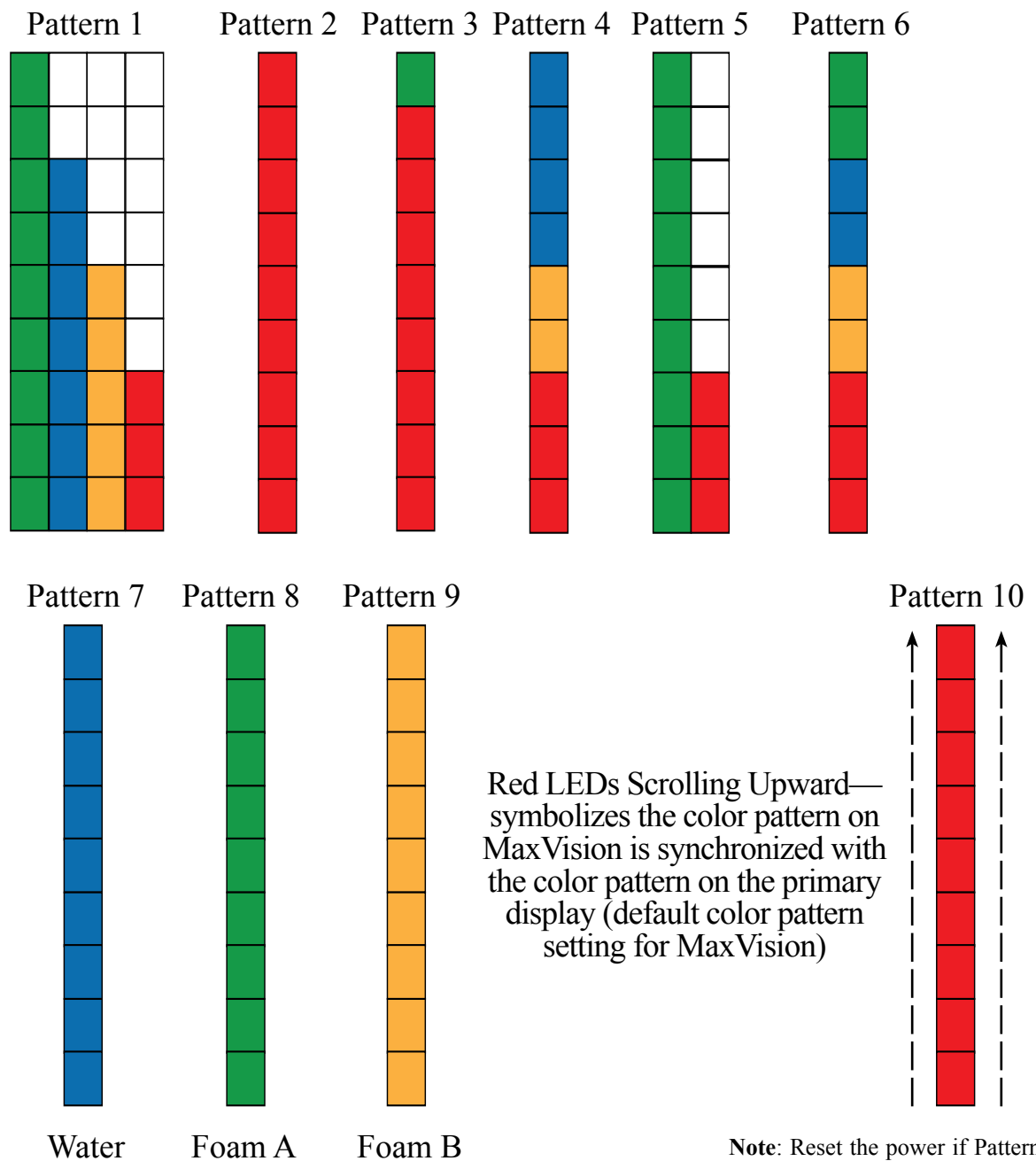

Figure 5. MaxVision Color Pattern Programming

Note: Do not use Loctite on any screws near the Lexan lens.
 Lexan lenses can become brittle and prone to cracking when exposed to Loctite compounds.

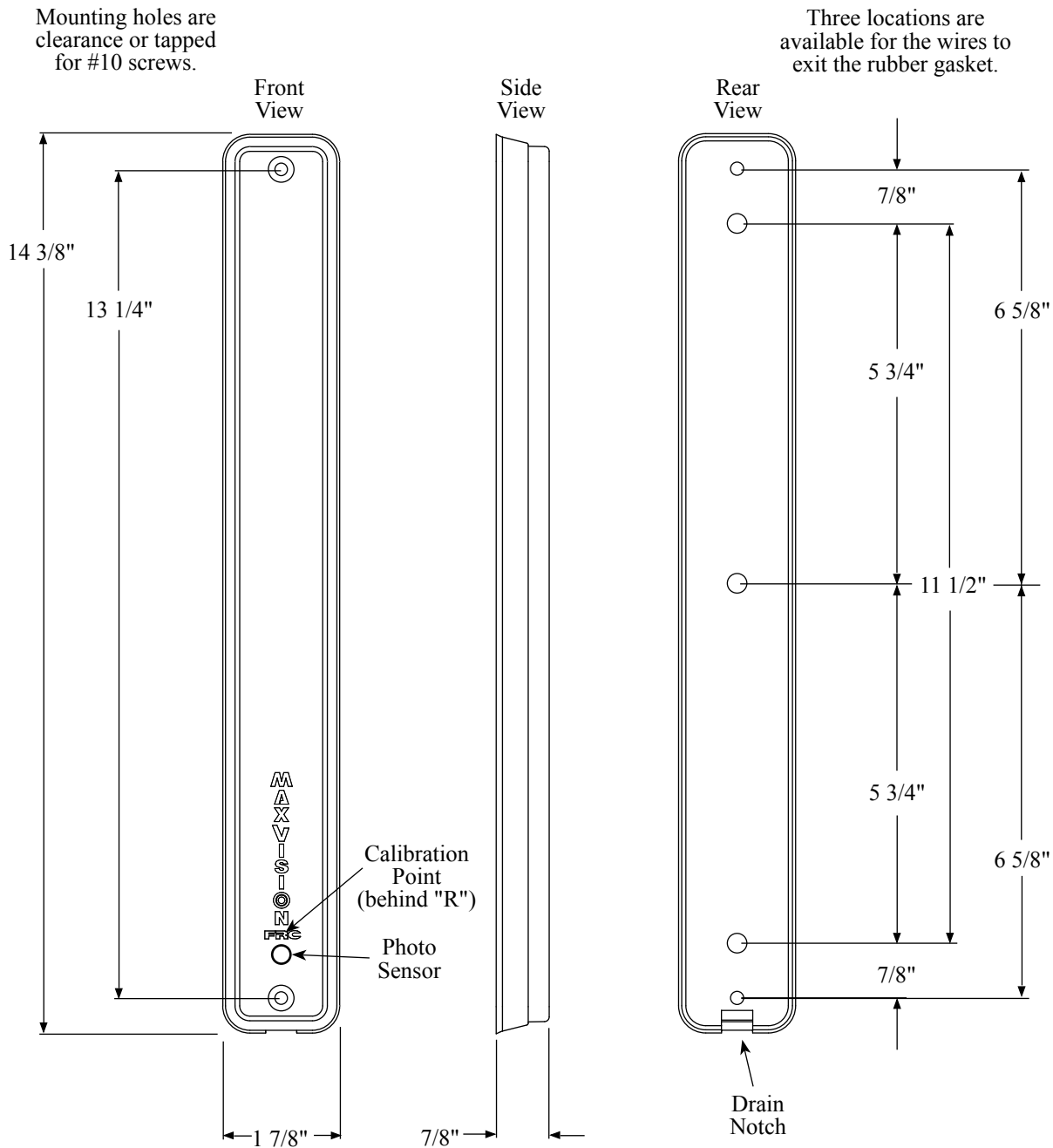
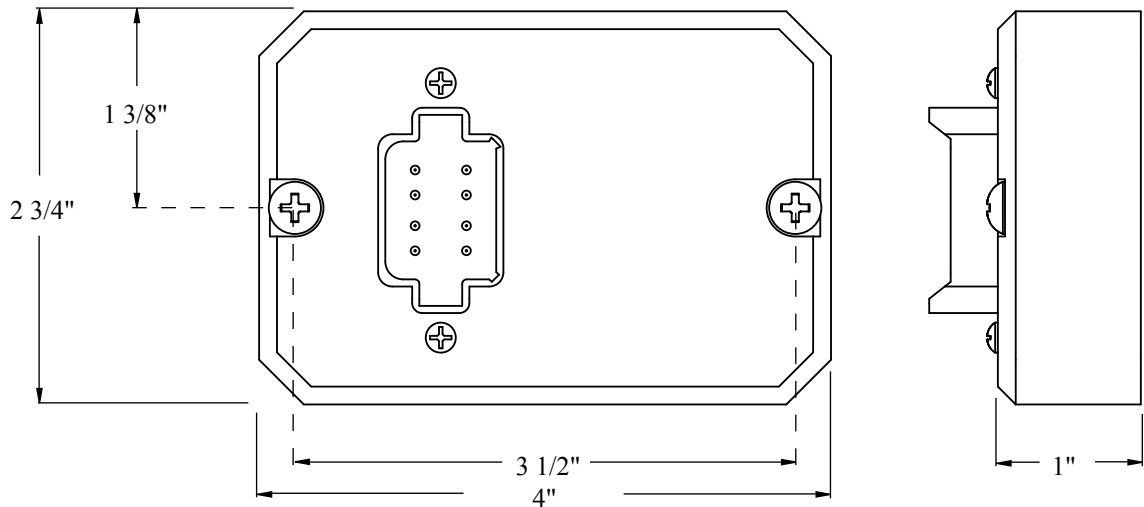

Figure 6. MaxVision LED Display Mounting Dimensions

Install Remote Light Driver

The remote light driver is water proof to allow for flexibility in the mounting location.

1. Measure and mark mounting location for light driver. Make sure there is clearance for driver and cable before drilling holes. Refer to Figure 5 for dimensions.
2. Drill and tap two 10-32 holes.
3. Secure remote light driver with two screws.
4. Connect cable and wires. (Refer to Wiring section.)



Install Buzzer

Install the buzzer close to the TankVisionPro so the audible warning is easily associated with the TankVisionPro. A cutout hole diameter of 1-1/4" is required. (Refer to the wiring section.)

Figure 7. Remote Light Driver

OPERATION

No operator input is required for the TankVisionPro to be operational. When power is on, the display is operating. The signal from the pressure sensor is processed and the volume of liquid in the tank shows on the display.

Note: Calibrating the TankVisionPro display to the tank is required before operations. (Refer to Calibration section.)

Primary Display Module

All LEDs are on when the tank is full. Each LED goes off starting at the top and working down as the liquid in the tank decreases.

The bottom 3 LEDs flash when the tank is less than 1/4 full. (For the WLA400 Series, the visual warning indicator signal is synchronized with the flashing LED on the display.)

All LEDs rapidly down-chase when the tank is almost empty.

Options

Programmable LED Display

LED Indicator lights can be programmed to be Red for all 9/10 rows, or one of the patterns shown on pages 27-29.

12 Pin Connector with Additional Features:

Visual warning output. (Active ground; Maximum 150mA)

Silence button input for audio warning only. (Active ground)

Separate Valve control output. (Active ground; Maximum 150mA)

Separate ground connection for the level sensor

Remote Display Module

The remote display repeats exactly what is shown on the master display.

Cab Miniature Display

All 5 LEDs is on when the tank is full. The LEDs will show full, 3/4, 1/2, 1/4, and empty tank.

MaxVision LED Display

The LED display repeats exactly what is shown on the master display.

Remote Light Driver

When power is applied, the remote light driver runs a lamp test function. The lamp test starts at the 1/4 light and cycles each remote light on and off. At the completion of the lamp test, the remote light driver turns on the correct light(s) to show the tank water or foam volume.

All four lights are on when the tank is full. The top light goes off as the tank starts to empty (at 7/8 full the light is off). The three bottom lights are on to show that the tank is between less than full (approx. 7/8 tank) and 1/2 tank. The bottom two lights show 1/2 and 1/4 tank. The bottom light blinks when the tank volume goes less than 1/4 tank.

Buzzer

The buzzer sounds when the tank volume drops to 1/4 tank. (*This is programmable. Review the Warning and Control Level Adjustment section on page 28 for detailed information.*)

CALIBRATION

The TankVisionPro has unique calibration programs that enable it to be used on tanks of all shapes and sizes.

Note: The standard pressure sensor is limited to a maximum tank height of ten feet.

Overview

Magnet Sensor

The calibration programs are accessed by activating the **C 1 and C 2** magnet sensors that are located on the front of the display module. The sensor is activated by placing the north or south pole of a small magnet in close proximity of the sensor. The magnet is then moved about (6) six inches inch away; this will produce an electronic signal that is similar to a button being released. If the LEDs in the display do not change, try moving the magnet further away from the sensor.

In these procedures, the term ‘swipe’ will mean to gently tap the magnet up to and then away from the magnetic sensor.

Non-Linear Calibration

The first program is a non-linear calibration procedure that can be used for any shape or size tank. This procedure must to be used for irregular shape tanks (e.g.: T-shape, oval, elliptical, tank with through hole, etc.). The program compares the pressure applied to the sensor, as the tank fills at a steady rate, to time. This provides for very accurate displays.

Linear Calibration

The second program is a linear calibration procedure that can only be used when the tank volume is proportional to the height. This would include square or rectangular shape tanks with no irregularities. It is quick way of calibrating a tank but not as accurate as the non-linear procedure. The program compares a full tank to an empty tank, takes the difference and divides it into eight equal volume displays.

PROGRAMMING CODES

Code Entry

1. Swipe the magnet at **C1**. Each of the bottom row of LEDs turns on one at a time.
2. Swipe the magnet at **C2**. Each of the top row of LEDs turns on one at a time.

For example:

- A. To enter Code 32, swipe the magnet at **C1** three times, and then swipe the magnet at **C2** twice.
 - B. If the code is accepted, the display will flash with the corresponding number of top and bottom LEDs as the entered count. For example—three bottom row and two top row LEDs will flash alternately between the top and bottom rows.
3. The process times out after 10 seconds of inactivity, or if no additional codes are entered (except for the non linear calibration).
 4. Save the new setting or enable new data entry by holding the magnet at **C2** until the display reacts.

Calibration and Tank Level Correction

Linear Tank Calibration

1. Start this process with a full tank.
2. Enter **Code 44** to activate the Linear tank calibration. (*See page 23 for detailed step-by-step instructions.*)

Nonlinear Tank Calibration

1. Start this process with an empty tank.
2. Enter **Code 33** to activate the Nonlinear tank calibration. (*See page 22 for detailed step-by-step instructions.*)

Non-Linear Calibration

This non-linear calibration procedure should be used for irregular shaped tanks. Start with an empty tank and fill at a steady rate of flow.

The term 'swipe' means to gently tap the magnet up to and then away from the **C 1 and C 2** sensors on front of the display.

Note: To exit the calibration mode without saving any new calibration, reset the power to the display.

1. Empty the tank.
2. Apply power to the display module.
3. Swipe the magnet three times at **C 1** three times (*3 LEDs light up at the bottom*) AND three times at **C 2** (*3 LEDs light up at the top*) to enter the calibration mode. Wait until the top three display LEDs and bottom three LEDs flash on and off.
4. Hold the magnet at **C 2** until a simulated fill pattern occurs on the display. This may NOT get to the FULL level.
5. Fill the tank *at a steady rate of flow*.

Note: As the tank is filling up, the display will simulate a visual "fill-up" light pattern.

6. Stop the flow 1-2 inches below the full level. Do NOT fill fluid into the fill tower. This will result in a false calibration
7. Hold the magnet at **C 2 until the display flashes** to set the calibration into memory.

Linear Calibration

This linear calibration procedure *can only be used for square or rectangular shaped tanks with no irregularities*. The calibration process requires that the tank to be full at the start of the procedure.

The term ‘swipe’ means to gently tap the magnet up to and then away from the **C 1** or **C 2** sensors on front of the display.

Note: To exit the calibration mode without saving any new calibration, reset the power to the display.

1. Fill the tank. (Do not fill up into the fill tower.)
2. Apply power to the display module.

Note: Once the calibration program is activated there is a six second time out. Do not wait more than six seconds to move from step 3 to step 4.

3. Swipe the magnet four times at **C 1** and four times at **C 2** to enter the calibration mode. (Do not wait more than six seconds in between swipes or the session will time out.)

Wait until the top four and bottom four display LEDs alternatively flash on and off. (See the diagram below.)

4. **While the LEDs are still flashing**, hold the magnet at **C 2** until the display reacts to set the calibration into memory.
5. After a few seconds the calibration process will terminate and all the LEDs will go on to show that the tank is full.

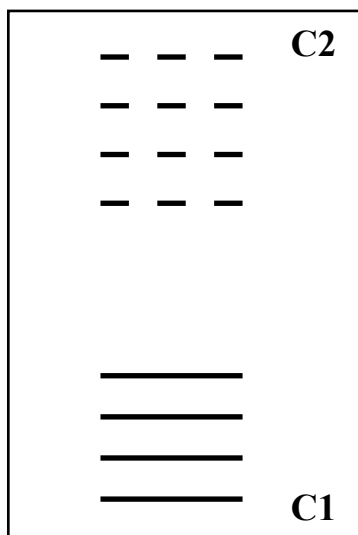

At Step 4 - Top four and bottom four LEDs will flash alternatively on and off

DIAGNOSTICS

There are diagnostic codes built into the TankVisionPro. These diagnostic codes can help in the troubleshooting process.

If there is no input on pin 2 of the remote light driver, the remote lights remain off.

The following **FAULTS** are displayed as long as the fault exists.

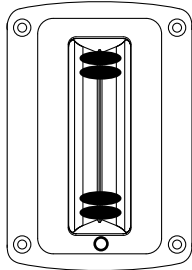
Display	Problem	Probable Cause
<p>Top 2 and Bottom 2 LEDs Alternately Flash.</p> 	<p>Pressure Sensor not detected at Primary Display (voltage < 0.3V)</p> <p>Datalink not detected at Remote Display</p>	<p>Sensor cable not connected Broken wire / bad connector on sensor cable Defective sensor</p> <p>Datalink cable not connected Broken wire / bad connector on datalink cable</p>

Top 4 and Bottom 4 LEDs Alternately Flash.

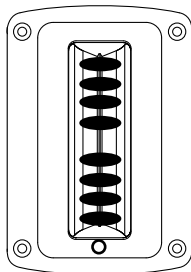

Pressure Sensor high output voltage. (voltage > 4.6V)

Shorted wire on sensor cable
Pressure Sensor or Primary Display Failure

The display cycles between normal and the following **WARNINGS** when a warning condition exists.

Display	Problem	Probable Cause
<p>Top and Bottom LEDs Blink ON and OFF</p> 	<p>The difference in voltage from the Pressure Sensor between tank empty and tank full is too small. (non-linear 3-swipes volt change less than 0.16V) (linear 4-swipes volt change less than 0.66V)</p>	<p>Illegal calibration procedure. Sensor cable not connected. Broken wire / bad connector on sensor cable. Tank height less then 6". Defective sensor.</p>

Figure 8. Diagnostics - Faults

The display cycles between normal and the following **WARNINGS** when a warning condition exists.

Display	Problem	Probable Cause
<p>CODE 66 Top 2 and Bottom 2 LEDs Blink ON and OFF</p> 	<p>If the voltage from the Pressure Sensor is more than 4.6 volts, then it is above normal range.</p>	<p>Apparatus at incline (parked on a hill). Not calibrated correctly. Shorted wire / bad connector on sensor cable.</p>

This high voltage warning can be enabled or disabled by swiping the **C 1** and **C 2** sensors six times. (Factory default setting: disabled.)

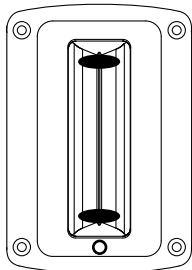
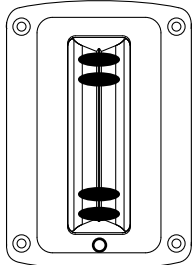
When **ENABLED** Top 2 and Bottom 2 LEDs Blink

When **DISABLED** Top 6 LEDs Blink

To change the setting swipe the **C 1** and **C 2** sensors six times again. Then hold the magnet at **C 2** for five seconds to set the calibration into memory.

To leave the setting as it is, let the processor time out and go back to normal display.

COLOR PATTERN SELECTION

- Code 11** Pattern 1 - One solid color. 4-green\3-blue\2-orange\1-red (*Default*)
- Code 12** Pattern 2 - All red (same as WLA-2XX Series)
- Code 13** Pattern 3 - Top 1/8 level is green and all others are red.
- Code 14** Pattern 4 - Three colors: blue\orange\red.
- Code 15** Pattern 5 - All green, and turns red when the **WARNING** is active (when the tank level is at or below 25%, or 1/4 full).
- Code 16** Pattern 6 - Four fixed colors for each 1/4 or 25% level: green\blue\orange\red.

Wait 5 seconds.

Save the new setting by holding the magnet at **C 2** for 5 seconds.

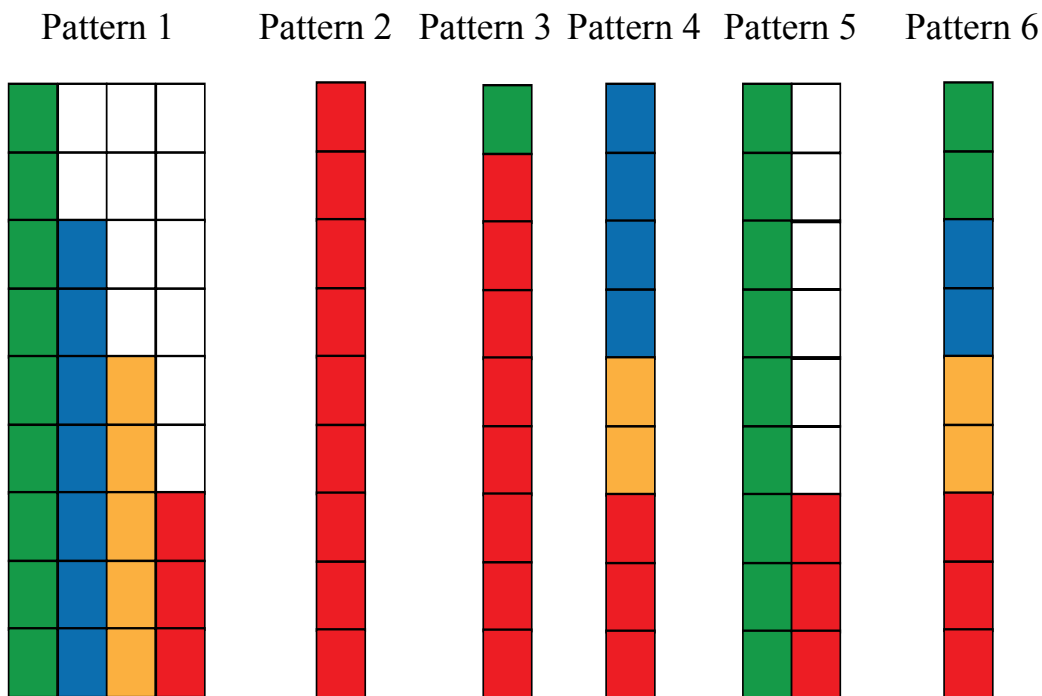

Note: The above is an example of a programmed LED Color Pattern.

Figure 10. Color Pattern Selection

Warning and Control Level Adjustment

Code Entry

1. Swipe the magnet at **C1**. Each of the bottom row of LEDs turns on one at a time.
2. Swipe the magnet at **C2**. Each of the top row of LEDs turns on one at a time.

For example:

- A. To enter Code 32, swipe the magnet at **C1** three times, and then swipe the magnet at **C2** twice.
 - B. If the code is accepted, the display will flash with the corresponding number of top and bottom LEDs as the entered count. For example—three bottom row and two top row LEDs will flash alternately between the top and bottom rows.
3. The process times out after 10 seconds of inactivity, or if no additional codes are entered (except for the non linear calibration).
 4. Save the new setting or enable new data entry by holding the magnet at **C2** for 5 seconds.

Code 21	To set the Audio warning level. Default—1/4 (25%)
Code 22	To set the Visual warning level. Default—1/4 (25%)
Code 23	To set the " Tank Full " audio signal level. Default—disabled.
Code 24	To set the Valve control signal " Low " activation level. Default— 1/2 (50%)
Code 25	To set the Valve control signal " Full " deactivation level. Default —7/8 (95%)
Code 26	To set the level for Audio warning to be turned off (or disabled). Default —1/4 (25%)
Code 27	To set the level for Visual warning to be turned off. Default —1/4 (25%)
Code 28	To set the delay time in seconds before the Audio warning is activated. Default —1 second (NOTE : each LED delays the Audio warning activation by 1 second. This is adjustable from 1 to 7 seconds.)

Figure 11. Diagnostics - Warnings

Level Adjustment Setting Pattern

1. Every magnet swipe at **C 1** will incrementally increase/decrease the activation value by 1/16 (5% for % scale).
2. Every Green LED is 1/8 level (10% for % scale).
3. Every blue LED is 1/16 level (5% for % scale).
4. LEDs are all red when activated, and show the default or previously set value.

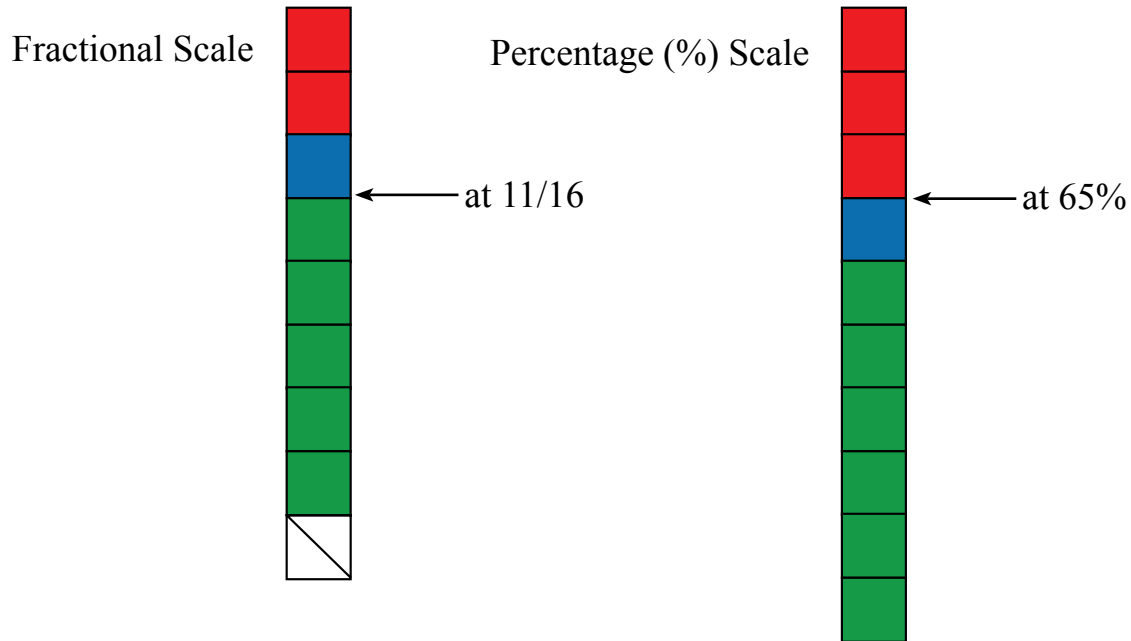

1. Enable the adjustment data entry by holding the magnet at **C 2** for 5 seconds. This sets the desired level for either Warnings or Valve Control setting activation.

Note: If the WL300 is set with code 24 and 25, the buzzer output will work as a valve controller.

Brightness Adjustment

Code 31 Day time brightness. Default—Brightness Level - 8

Code 32 Night time brightness. Default—Brightness Level - 2

1. Every magnet swipe at **C 1** will incrementally increase/decrease the brightness for 10 various levels.
2. Starting from the lowest level, repeat the process from number 1.
3. Enable the data entry by holding the magnet at **C 2** for 5 seconds.
4. Adjust the brightness to the desired level.
5. Save the new setting by holding the magnet at **C 2** for 5 seconds.

Primary and Remote Synchronization

If the level pressure sensor is detected, (0.3V or more) the unit will work as a Primary display. Any remote unit including Water, Foam A, or Foam B, and MaxVision, that is connected via CAN bus will be synchronized with following settings:

- Tank level calibration
- Display Pattern
- Warning and control activation levels

NOTE: Brightness will remain as adjusted locally in the remote display unit.

WIRING

Primary Display (WLA3XX/WLA4XX)

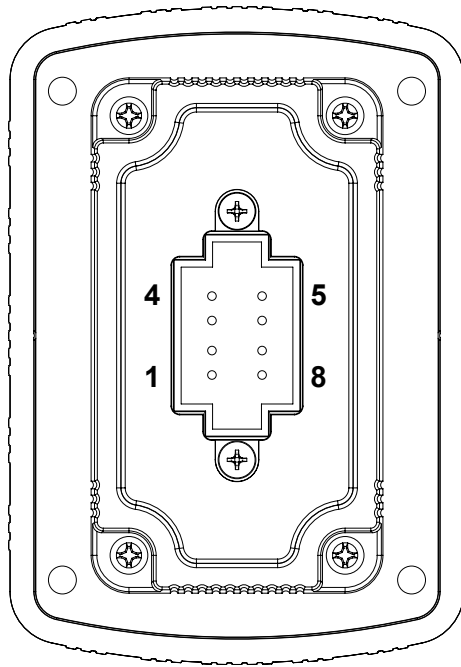

WLA3XX Primary Display Connector

Pin	Description
1	Power 9-30 VDC
2	Ground (Sensor Ground)
3	Sensor 5 VDC
4	Sensor Signal
5	Buzzer Ground (150mA)
6	Display Signal Out
7	Datalink (+)
8	Datalink (-)

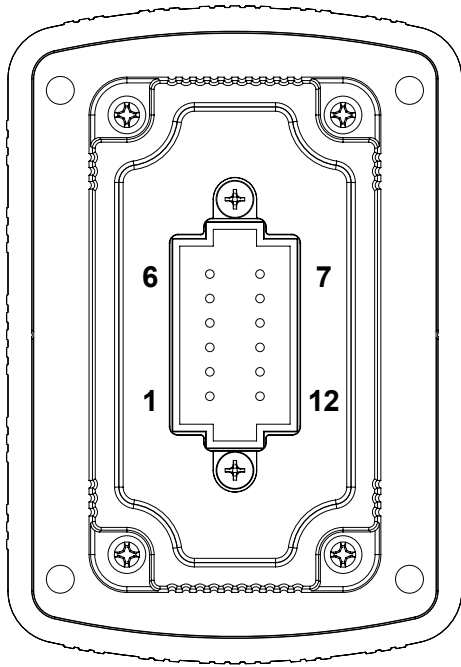

WLA4XX Primary Display Connector

Pin	Description
1	Power 9-30 VDC
2	Ground
3	Sensor 5 VDC
4	Sensor Signal
5	Buzzer Ground (150mA)
6	Display Signal Out
7	Datalink (+)
8	Datalink (-)
9	Silence Button Input
10	Sensor Ground
11	Valve Control Output (150 mA)
12	Visual Warning Ground (150 mA)

Figure 12. Primary Display Wiring

WIRING

Primary Display Rear View (WLA3XX/WLA4XX)

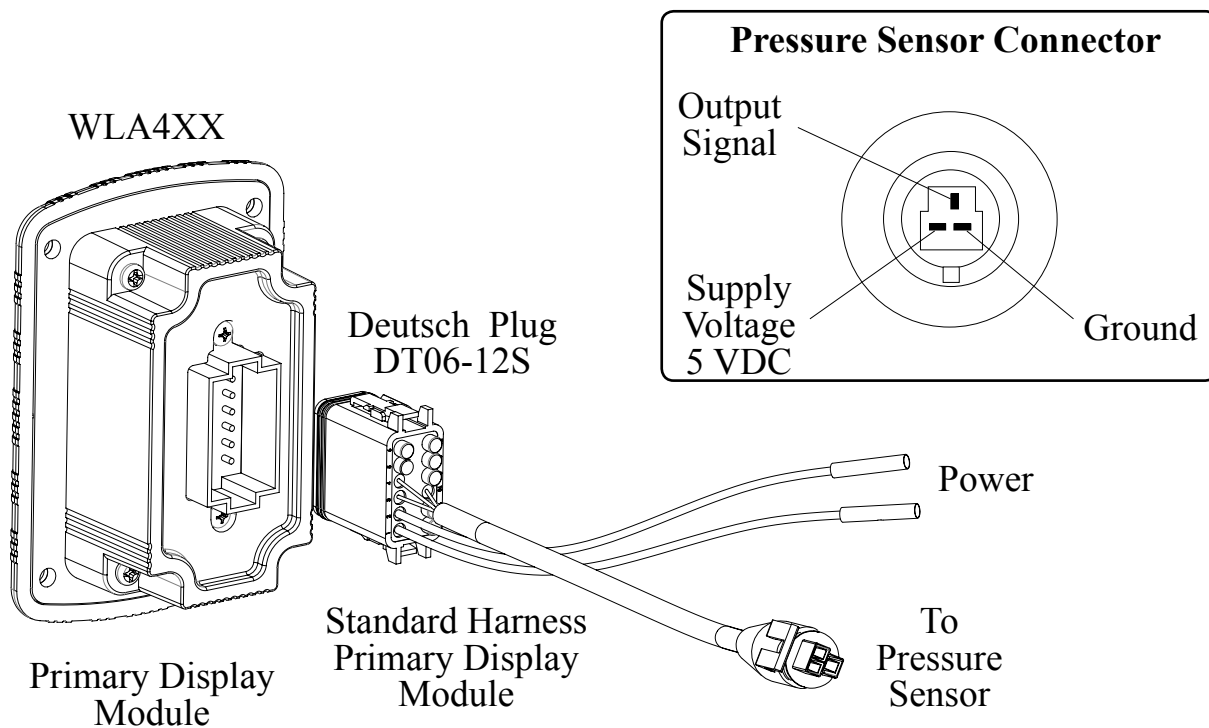
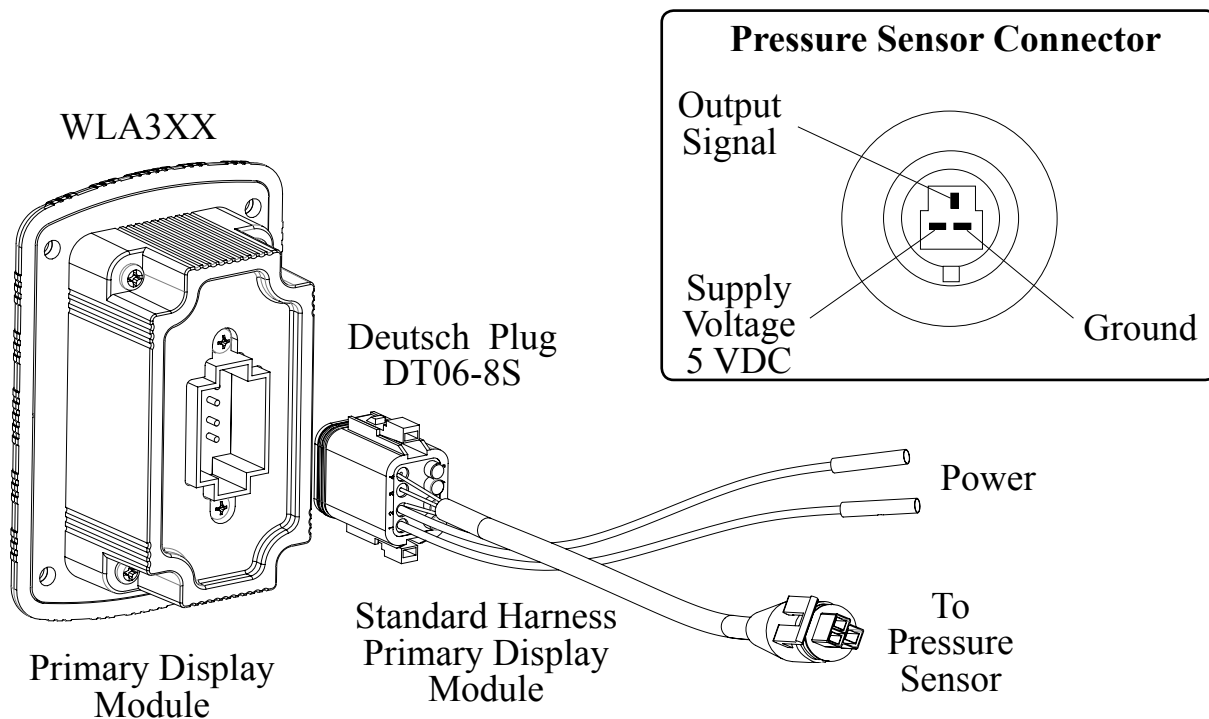

Figure 13. Primary Display Wiring (Rear View)

Remote Displays (WLA3XX/WLA4XX)

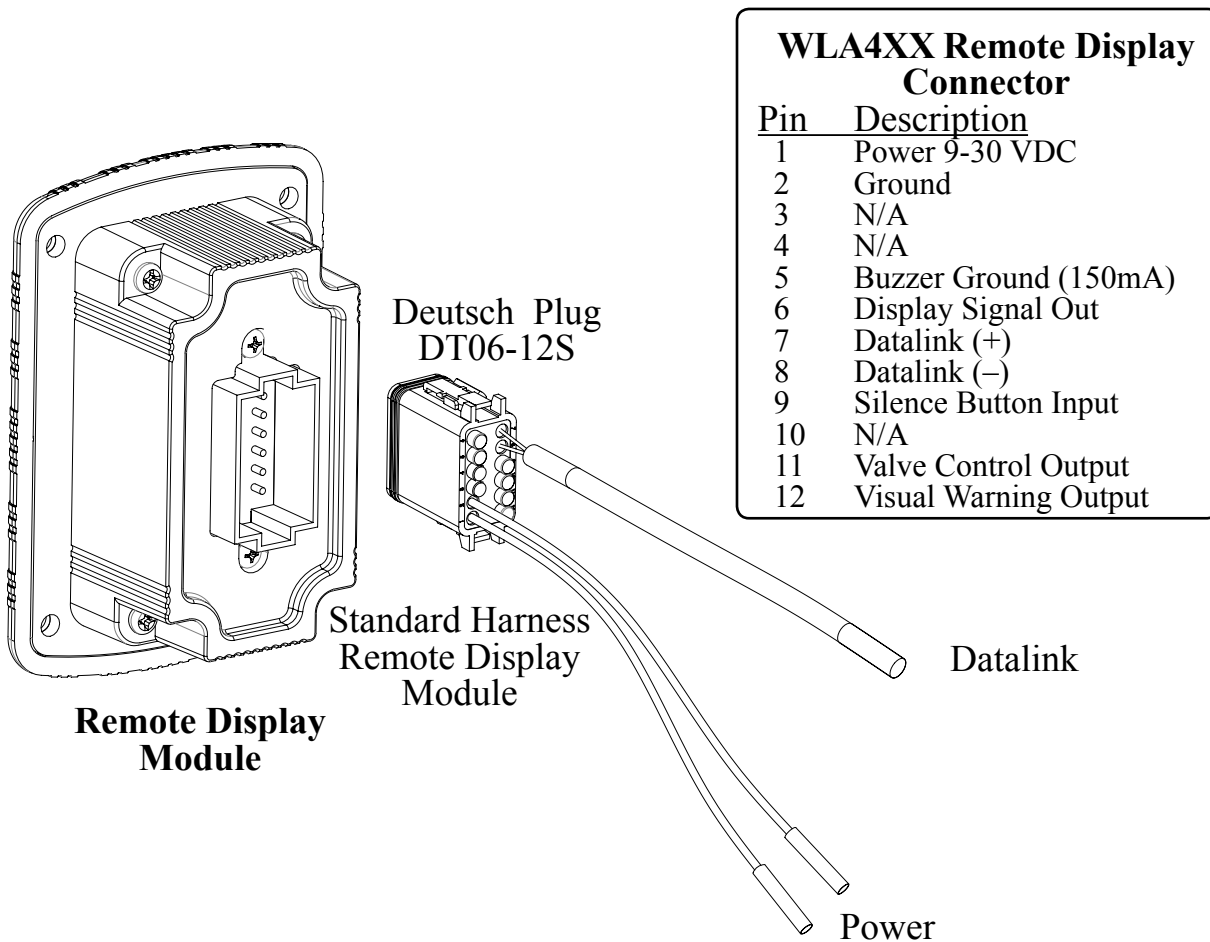
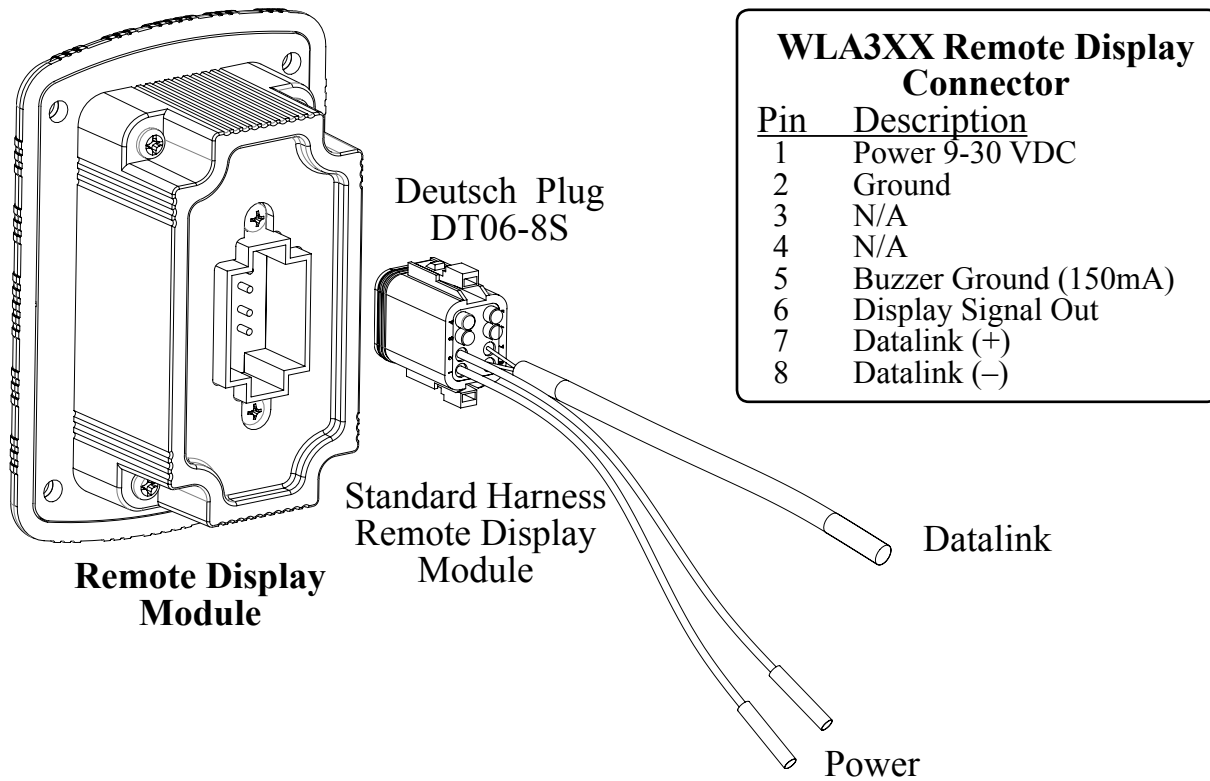
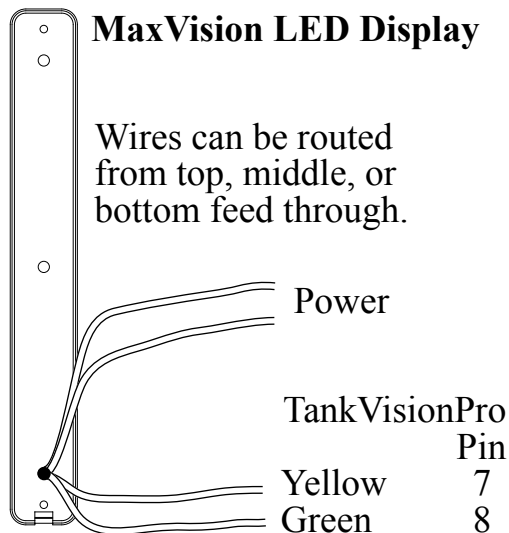
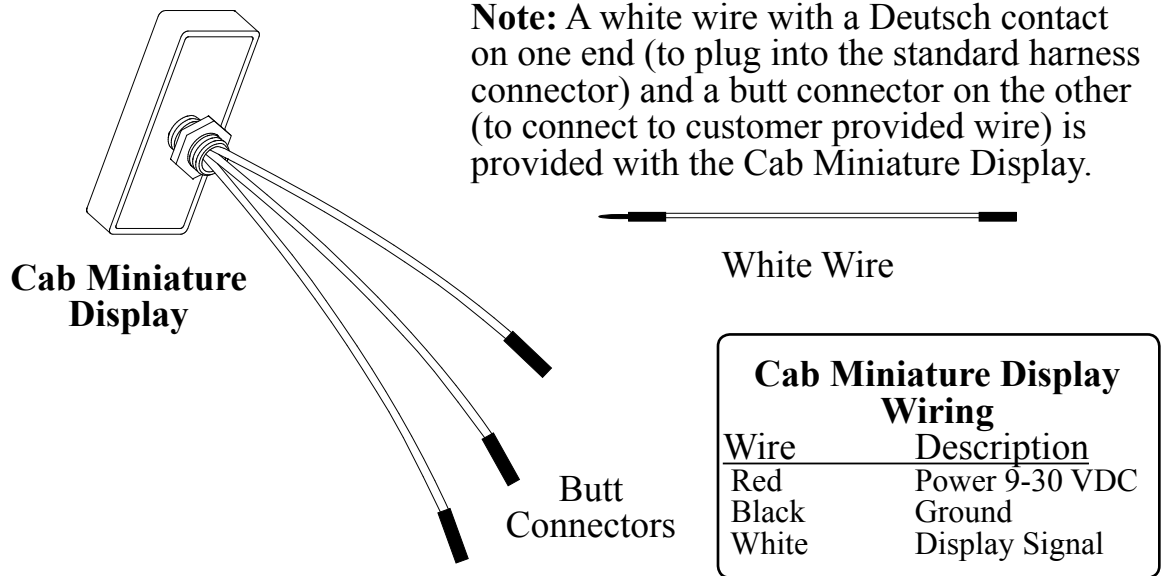

Figure 14. Remote Display Wiring (WLA3XX/WLA4XX)

Cab Miniature and MaxVision LED Displays



Note: See *Terminating Resistor Notes* for the MaxVision on page 15.

Note: A terminating resistor kit is included with the MaxVision LED display.

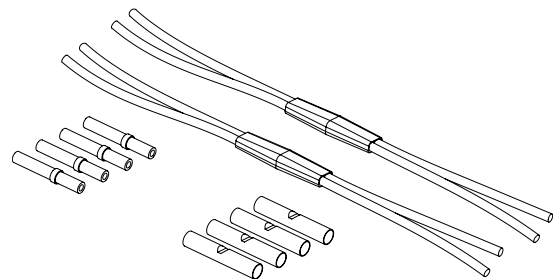

Figure 15. Cab Miniature and LED Display Wiring

Remote Light Driver

Notes:

Connect a wire from the primary or a remote display module pin 6 to the remote light driver pin 2 (this is the input signal to the remote driver). If there is no signal on pin 2 the lights remain off.

Connect power to pin 3 and to pin 8, this is power for the remote driver and the remote lights. It is recommended that pin 3 and pin 8 be tied together. The maximum current is 20 AMPS @ 12VDC (10 AMPS @ 24 VDC).

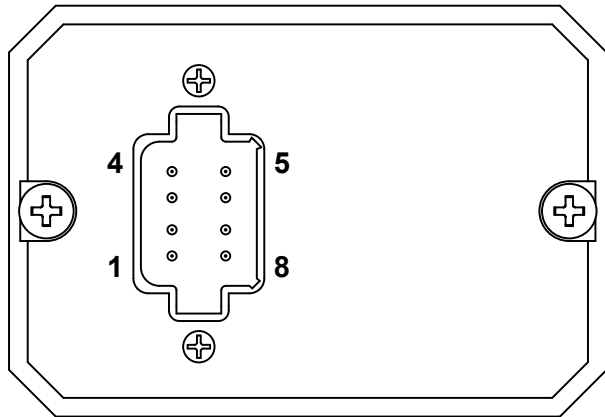

Light Driver Connector	
Pin	Signal Description
1	Ground
2	Signal Input
3*	Remote Light Power
4	1/4 Tank Output
5	1/2 Tank Output
6	3/4 Tank Output
7	Full Tank Output
8*	Remote Light Power

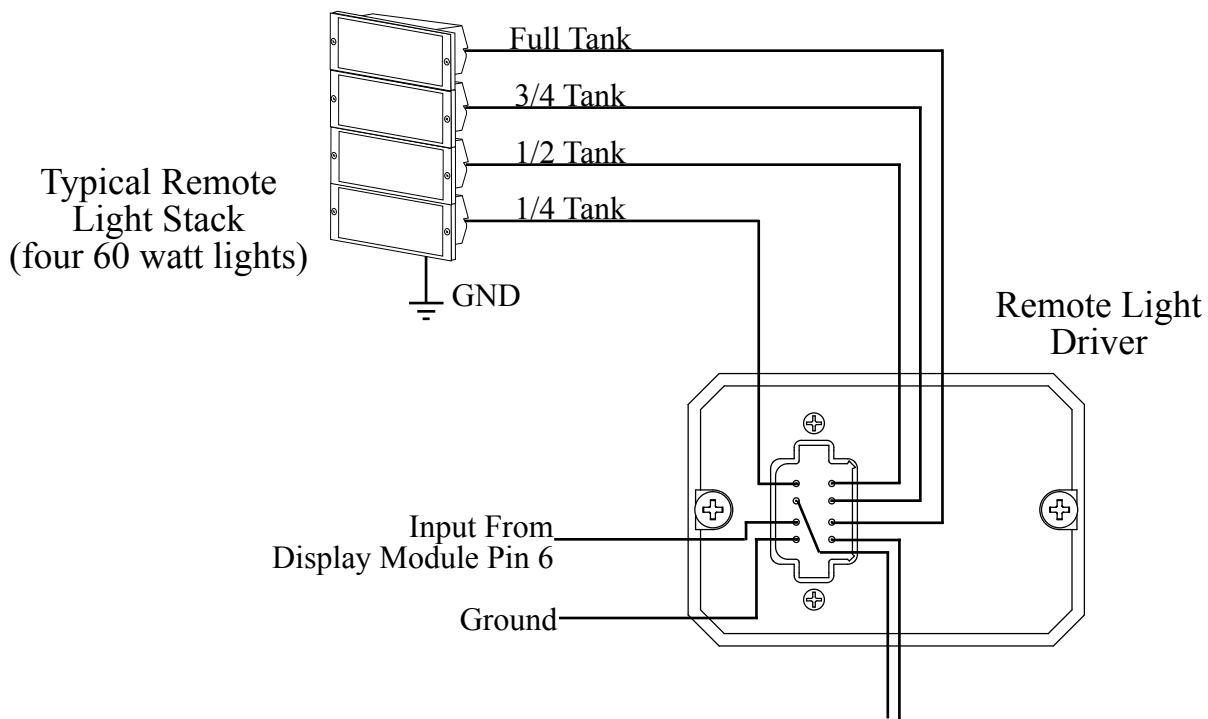

Note: If there is no signal on pin 2 (input from a display module) the lights remain off.

*Light Power
 (12 VDC 20 A)
 (24 VDC 10 A)
 Use 16 AWG Wire

Figure 16. Remote Light Driver Wiring

Typical System Configuration WLA3XX

Note: Multiple number of remote displays can be connected to the primary display. Any remote display can become a primary by disconnecting the sensor from the primary and connecting it to the remote.

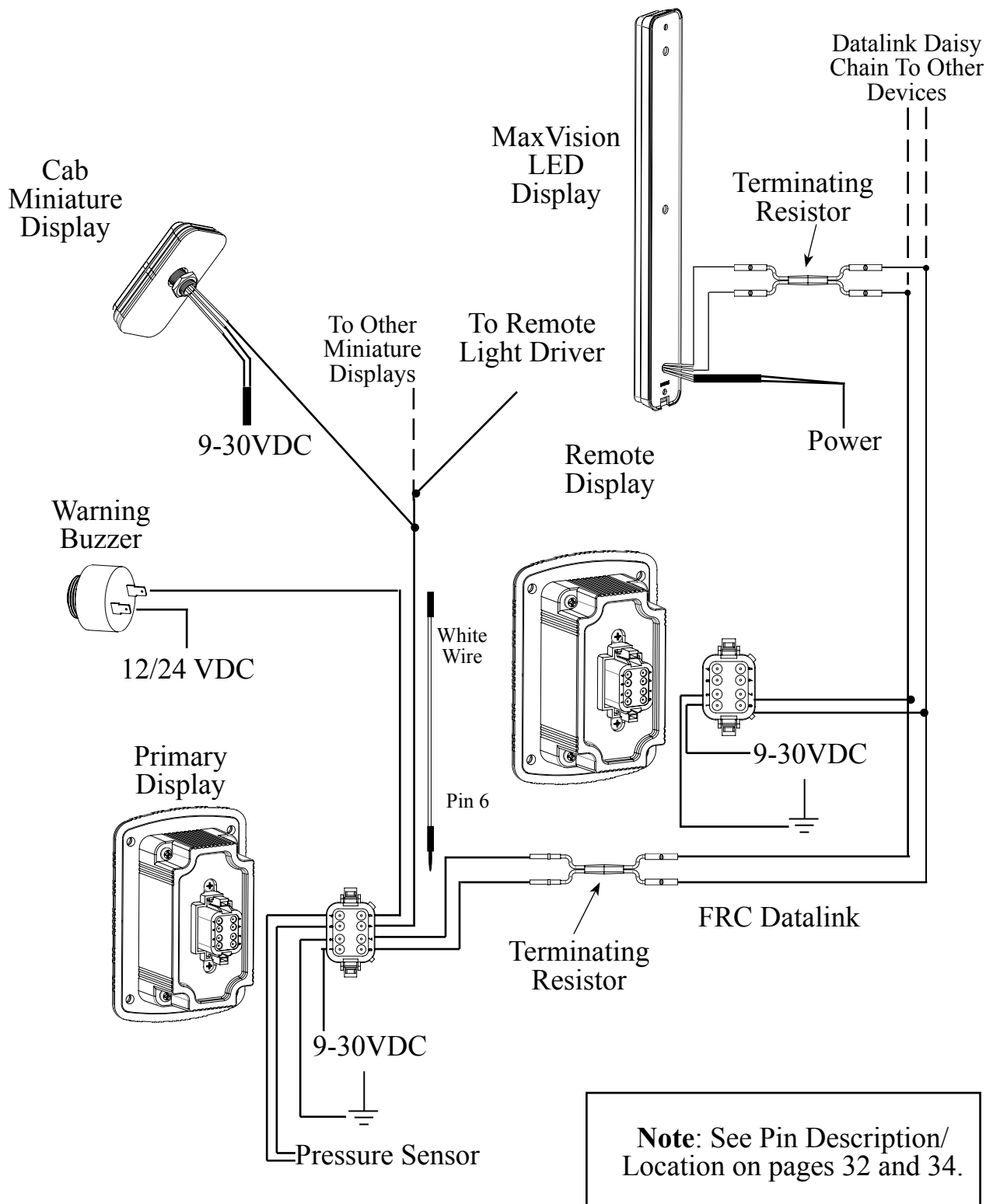
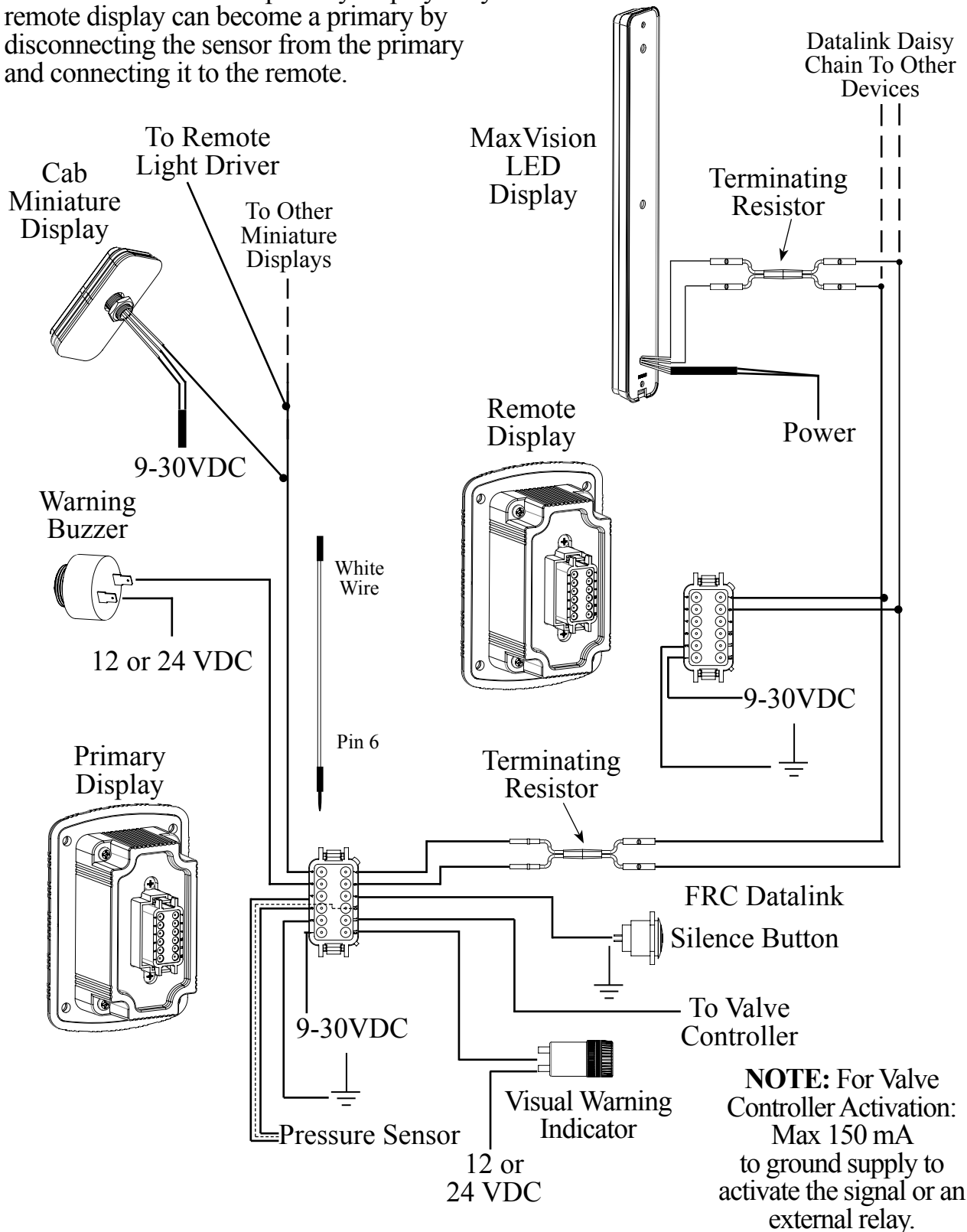

Figure 17. Typical System Configuration WLA3XXX

Typical System Configuration WLA4XX

Note: Multiple number of remote displays can be connected to the primary display. Any remote display can become a primary by disconnecting the sensor from the primary and connecting it to the remote.



NOTE: For Valve Controller Activation: Max 150 mA to ground supply to activate the signal or an external relay.

Note: See Pin Description/ Location on pages 32 and 34.

Figure 18. Typical System Configuration WLA4XXX

CLEAN/INSPECT PRESSURE/VACUUM FOAM TANK VENT

The pressure/vacuum foam tank valve is supplied for use on sealed foam tanks.

There are internal passageways that provide a path for air to move between the tank and a center cavity in the vent. These passageways are self-draining and designed to prevent splashing foam from entering the center cavity and clogging the pressure and vacuum valves.

The pressure and vacuum valves are easily accessed and disassembled for periodic cleaning or inspections. Unscrew the cap from the main body and lift the valves out of the center cavity. Clean all parts with warm water.

Note: The internal pressure and vacuum valves are different sizes. Make sure to reassemble these valves correctly.

Note: It is extremely important that the pressure and vacuum valves are assembled correctly.

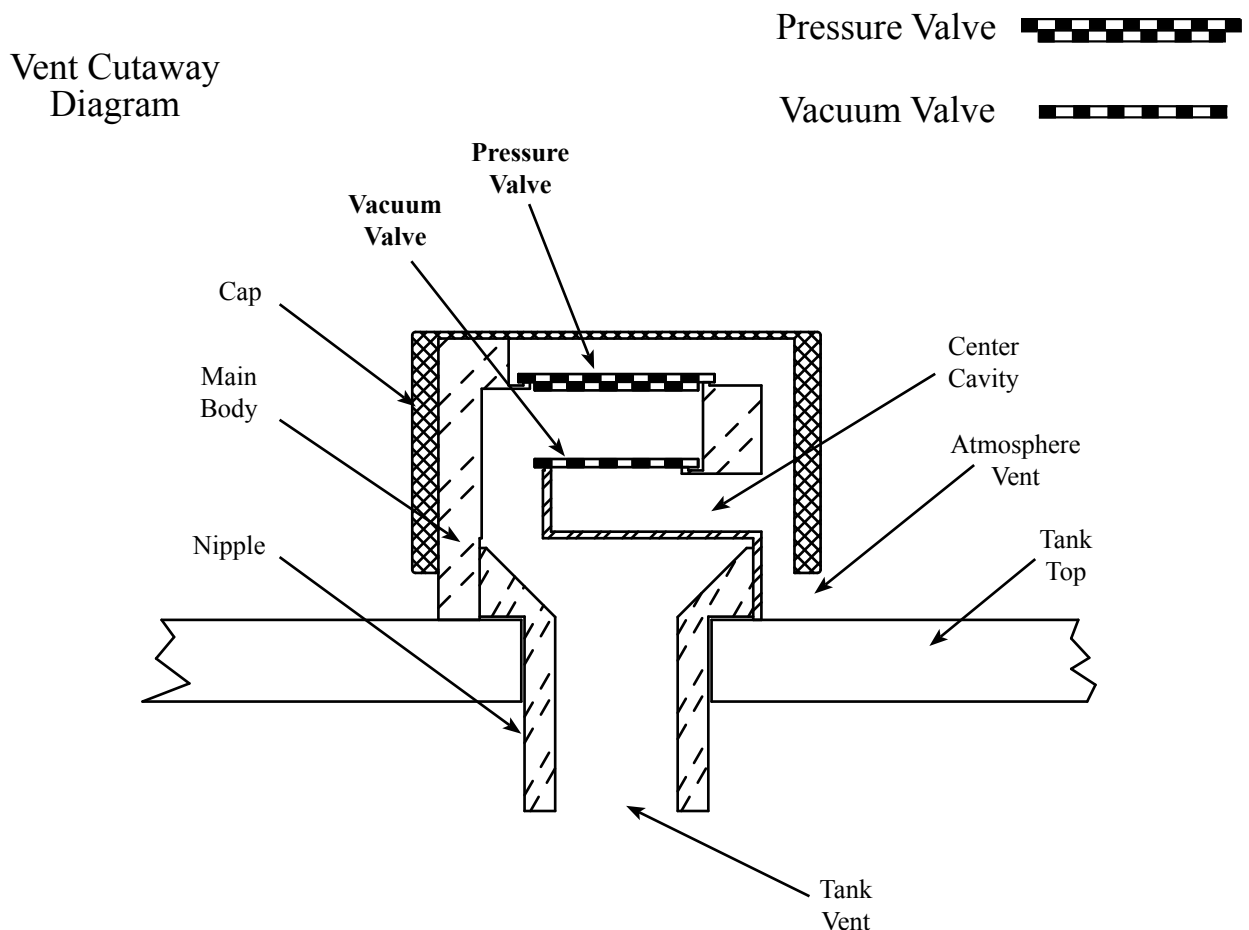

Figure 19. Clean and Inspect Pressure/Vacuum Foam Tank Vent

WLA300 Standard Parts List

INDEX	PART NO.	DESCRIPTION
-	WLA300	TankVisionPro Kit, Water
-	WLA360	TankVisionPro Kit, Class A Foam
-	WLA370	TankVisionPro Kit, Class B Foam
1	XE-WL300-D	Display Module, Water
	XE-WL360-D	Display Module, Class A Foam
	XE-WL370-D	Display Module, Class B Foam
2	XE-WL200S-CXXA	Primary Display Cable, XX=Length
3	XE-WL200R-CXXA	Remote Display Cable, XX=Length
4	XE-WLPT4-S	Pressure Sensor
5	XE-WL20A-A	Thin Wall Adapter Kit
6	XE-WL400-A	Foam Vent, Vertical Mount
7	XE-WL400H-A	Foam Vent, 90 Degree Mount
8	WLA205	Cab Miniature, Water
8	WLA265	Cab Miniature, Class A Foam
8	WLA275	Cab Miniature, Class B Foam
9	WLA290	Remote Light Driver
-	XE-WLE08-A	White Wire w/Deutsch Pin and Butt Connector
10	WLA280	MaxVision LED Tank Display
11	XE-XXDLTERMW-A0A	Accessory Kit TV Data-Link 2 Term. Resistors w/Wires

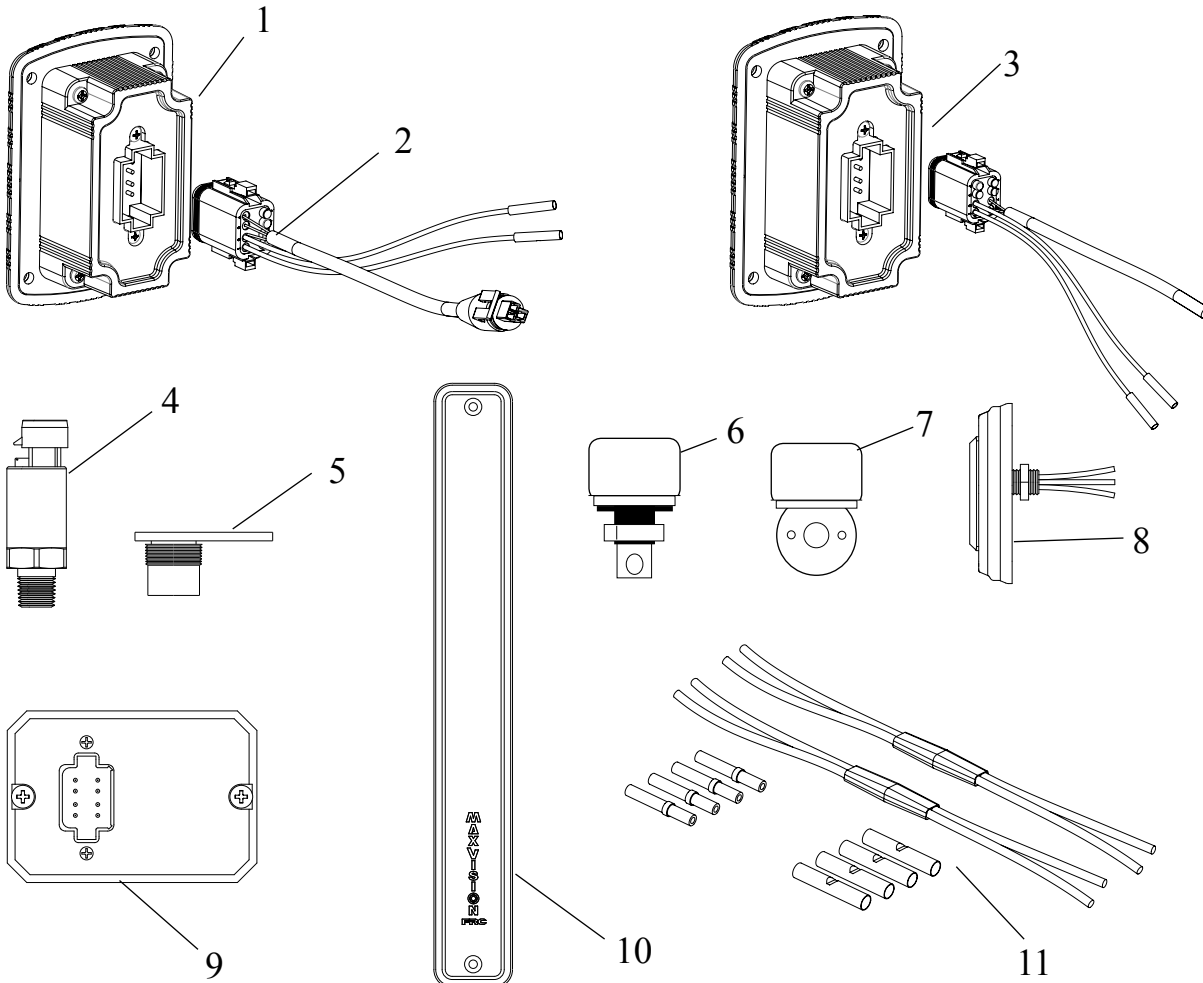

Figure 20. WLA300 Parts List

WLA400 Standard Parts List

INDEX	PART NO.	DESCRIPTION
-	WLA400	TankVisionPro Kit, Water
-	WLA460	TankVisionPro Kit, Class A Foam
-	WLA470	TankVisionPro Kit, Class B Foam
1	XE-WL400-D	Display Module, Water
1	XE-WL460-D	Display Module, Class A Foam
1	XE-WL470-D	Display Module, Class B Foam
2	XE-WL400S-CXXA	Primary Display Cable, XX=Length
3	XE-WL400R-CXXA	Remote Display Cable, XX=Length
4	XE-WLPT4-S	Pressure Sensor
5	XE-WL20A-A	Thin Wall Adapter Kit
6	XE-WL400-A	Foam Vent, Vertical Mount
7	XE-WL400H-A	Foam Vent, 90 Degree Mount
8	WLA205	Cab Miniature, Water
8	WLA265	Cab Miniature, Class A Foam
8	WLA275	Cab Miniature, Class B Foam
9	WLA290	Remote Light Driver
-	XE-WLE08-A	White Wire w/Deutsch Pin and Butt Connector
10	WLA280	MaxVision LED Tank Display
11	XE-XXDLTERMW-A0A	Accessory Kit TV Data-Link 2 Term. Resistors w/Wires

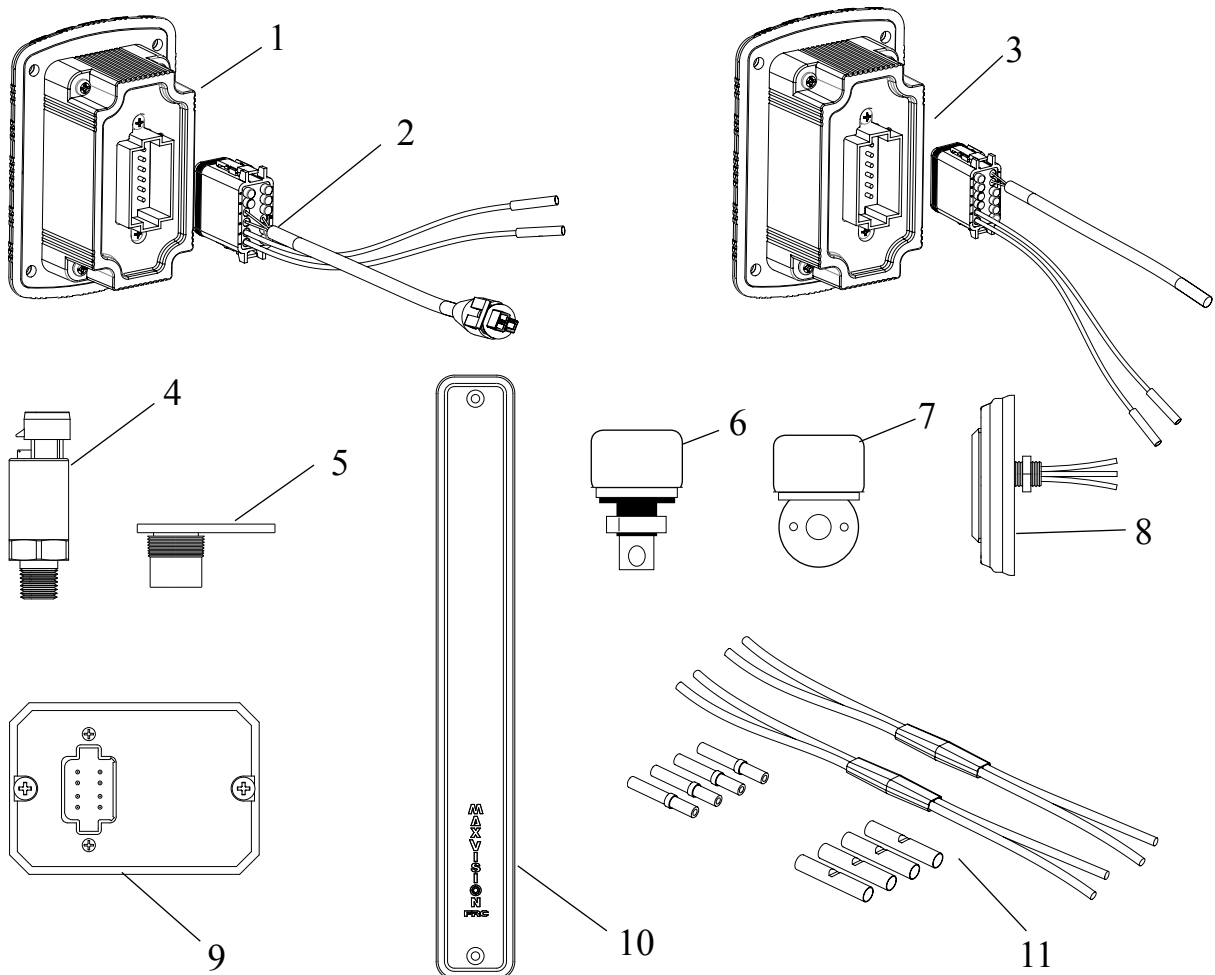

Figure 21. WLA400 Parts List

NOTES

NOTES



DANGER

PERSONAL RESPONSIBILITY CODE

The member companies of FEMSA that provide emergency response equipment and services want responders to know and understand the following:

1. Firefighting and Emergency Response are inherently dangerous activities requiring proper training in their hazards and the use of extreme caution at all times.
2. It is your responsibility to read and understand any user's instructions, including purpose and limitations, provided with any piece of equipment you may be called upon to use.
3. It is your responsibility to know that you have been properly trained in Firefighting and/or Emergency Response and in the use, precautions, and care of any equipment you may be called upon to use.
4. It is your responsibility to be in proper physical condition and to maintain the personal skill level required to operate any equipment you may be called upon to use.
5. It is your responsibility to know that your equipment is in operable condition and has been maintained in accordance with the manufacturer's instructions.
6. Failure to follow these guidelines may result in death, burns or other severe injury.



Fire and Emergency Manufacturers and Services Association, Inc.
P.O. Box 147, Lynnfield, MA 01940 www.FEMSA.org

Copyright 2006 FEMSA. All Rights Reserved